

BCH2MM0913CA6C

servo motor BCH, Lexium 28, 130mm, 900W, 9.7kg.cm², with oil seal, with key, straight connection



Main

Range compatibility	Lexium 28
Device short name	BCH2
Product or component type	Servo motor

Complementary

Maximum mechanical speed	3000 rpm
[Us] rated supply voltage	220 V
Network number of phases	Single phase Three phase
Continuous stall current	5.64 A
Continuous stall torque	8.59 N.M for LXM26D at 7 A, 220 V, single phase 8.59 N.M for LXM26D at 7 A, 220 V, three phase 8.59 N.M for LXM28... at 7 A, 220 V, single phase 8.59 N.m for LXM28... at 7 A, 220 V, three phase
Continuous power	900 W
Peak stall torque	25.77 N.M for LXM26D at 7 A, 220 V, single phase 25.77 N.M for LXM26D at 7 A, 220 V, three phase 25.77 N.M for LXM28... at 7 A, 220 V, single phase 25.77 N.m for LXM28... at 7 A, 220 V, three phase
Nominal output power	900 W for LXM26D at 7 A, 220 V, single phase 900 W for LXM26D at 7 A, 220 V, three phase 900 W for LXM28... at 7 A, 220 V, single phase 900 W for LXM28... at 7 A, 220 V, three phase
Nominal torque	8.59 N.M for LXM26D at 7 A, 220 V, single phase 8.59 N.M for LXM26D at 7 A, 220 V, three phase 8.59 N.M for LXM28... at 7 A, 220 V, single phase 8.59 N.m for LXM28... at 7 A, 220 V, three phase
Nominal speed	1000 rpm for LXM26D at 7 A, 220 V, single phase 1000 rpm for LXM26D at 7 A, 220 V, three phase 1000 rpm for LXM28... at 7 A, 220 V, single phase 1000 rpm for LXM28... at 7 A, 220 V, three phase
Maximum current Irms	19.81 A for LXM28... at 0.9 kW, 220 V
Maximum permanent current	6.15 A
Product compatibility	LXM26D servo drive motor at 0.9 kW, 220 V, single phase LXM26D servo drive motor at 0.9 kW, 220 V, three phase LXM28... servo drive motor at 0.9 kW, 220 V, single phase LXM28... servo drive motor at 0.9 kW, 220 V, three phase
Shaft end	Keyed
Shaft diameter	22 mm
Shaft length	55 mm
Key width	8 mm
Feedback type	20 bits single turn absolute encoder
Holding brake	Without

Mounting support	Asian standard flange
Motor flange size	130 mm
Electrical connection	Connector MIL
Torque constant	1.52 N.m/A at 20 °C
Back emf constant	92 V/krpm at 20 °C
Rotor inertia	9.7 kg.cm ²
Stator resistance	1.19 Ohm at 20 °C
Stator inductance	14.9 mH at 20 °C
Stator electrical time constant	12.52 ms at 20 °C
Maximum radial force Fr	670 N at 1000 rpm
Maximum axial force Fa	200 N
Brake pull-in power	19.7 W
Type of cooling	Natural convection
Length	163 mm
Number of motor stacks	2
Centring collar diameter	110 mm
Centring collar depth	8 mm
Number of mounting holes	4
Mounting holes diameter	9.2 mm
Circle diameter of the mounting holes	145 mm
Distance shaft shoulder-flange	8 mm
Net weight	7.6 kg

Environment

IP degree of protection	IP50 IM V3 IP65 IM B5, IM V1
Ambient air temperature for operation	-20...40 °C

Packing Units

Unit Type of Package 1	PCE
Number of Units in Package 1	1
Package 1 Height	18.1 cm
Package 1 Width	23.0 cm
Package 1 Length	36.0 cm
Package 1 Weight	17.55 kg
Unit Type of Package 2	CAR
Number of Units in Package 2	9
Package 2 Height	73.0 cm
Package 2 Width	60.0 cm
Package 2 Length	80.0 cm
Package 2 Weight	157.95 kg

Offer Sustainability

Sustainable offer status	Green Premium product
REACH Regulation	REACH Declaration
REACH free of SVHC	Yes
EU RoHS Directive	Pro-active compliance (Product out of EU RoHS legal scope)
Mercury free	Yes
China RoHS Regulation	China RoHS Declaration
RoHS exemption information	Yes
Environmental Disclosure	Product Environmental Profile
Circularity Profile	End Of Life Information

WEEE	The product must be disposed on European Union markets following specific waste collection and never end up in rubbish bins
PVC free	Yes

Dimensions

Dimensions of Motor

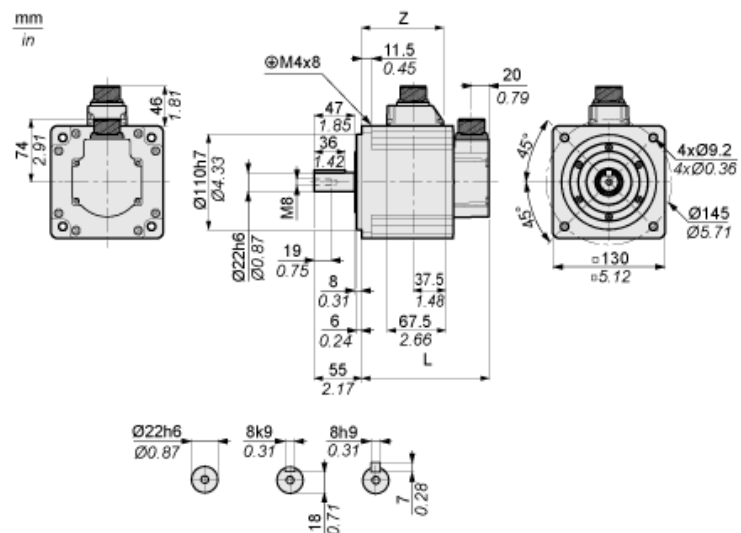

	mm	in.
L (without holding brake)	163	6.42
L (with holding brake)	198	7.8
Z	110.5	4.35

Torque/Speed Curves with 230 V Single/Three Phase Supply Voltage

Servo Motor with LXM28AU10●●● Servo Drive

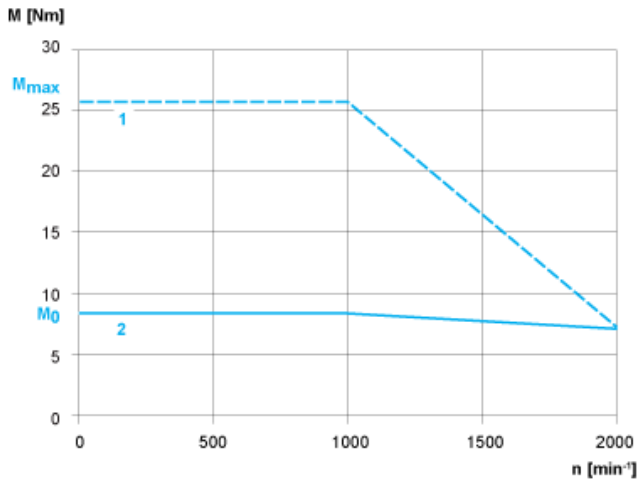

- 1 : Peak torque
- 2 : Continuous torque