



Main

Range compatibility	Lexium 28
Device short name	BCH2
Product or component type	Servo motor

Complementary

Maximum mechanical speed	3000 rpm
[Us] rated supply voltage	220 V
Network number of phases	Three phase
Continuous stall current	16.55 A
Continuous stall torque	16.7 N.m for LXM28... at 22.9 A, 220 V, three phase
Continuous power	3500 W
Peak stall torque	50.3 N.m for LXM28... at 22.9 A, 220 V, three phase
Nominal output power	3500 W for LXM28... at 22.9 A, 220 V, three phase
Nominal torque	16.7 N.m for LXM28... at 22.9 A, 220 V, three phase
Nominal speed	2000 rpm for LXM28... at 22.9 A, 220 V, three phase
Maximum current Irms	57.8 A for LXM28... at 3.5 kW, 220 V
Maximum permanent current	19 A
Product compatibility	LXM28... servo drive motor at 3.5 kW, 220 V, three phase
Shaft end	Smooth shaft
Shaft diameter	35 mm
Shaft length	79 mm
Feedback type	20 bits single turn absolute encoder
Holding brake	With
Holding torque	48 N.m built-in
Mounting support	Asian standard flange
Motor flange size	180 mm
Electrical connection	Connector MIL
Torque constant	1.01 N.m/A at 20 °C
Back emf constant	61 V/krpm at 20 °C
Rotor inertia	54.1 kg.cm ²
Stator resistance	0.157 Ohm at 20 °C
Stator inductance	2.93 mH at 20 °C
Stator electrical time constant	18.66 ms at 20 °C
Maximum radial force Fr	1200 N at 2000 rpm
Maximum axial force Fa	497 N
Brake pull-in power	49.6 W
Type of cooling	Natural convection
Length	235 mm

Number of motor stacks	2
Centring collar diameter	114.3 mm
Centring collar depth	4 mm
Number of mounting holes	4
Mounting holes diameter	13.5 mm
Circle diameter of the mounting holes	200 mm
Distance shaft shoulder-flange	4 mm
Net weight	23 kg

Environment

IP degree of protection	IP50 IM V3 IP65 IM B5, IM V1
Ambient air temperature for operation	0...40 °C

Packing Units

Unit Type of Package 1	PCE
Number of Units in Package 1	1
Package 1 Height	24.5 cm
Package 1 Width	29.0 cm
Package 1 Length	58.5 cm
Package 1 Weight	24.63 kg

Offer Sustainability

Sustainable offer status	Green Premium product
REACH Regulation	REACH Declaration
REACH free of SVHC	Yes
EU RoHS Directive	Pro-active compliance (Product out of EU RoHS legal scope)
Mercury free	Yes
China RoHS Regulation	China RoHS Declaration
RoHS exemption information	Yes
Environmental Disclosure	Product Environmental Profile
Circularity Profile	End Of Life Information
WEEE	The product must be disposed on European Union markets following specific waste collection and never end up in rubbish bins

Dimensions

Dimensions of Motor

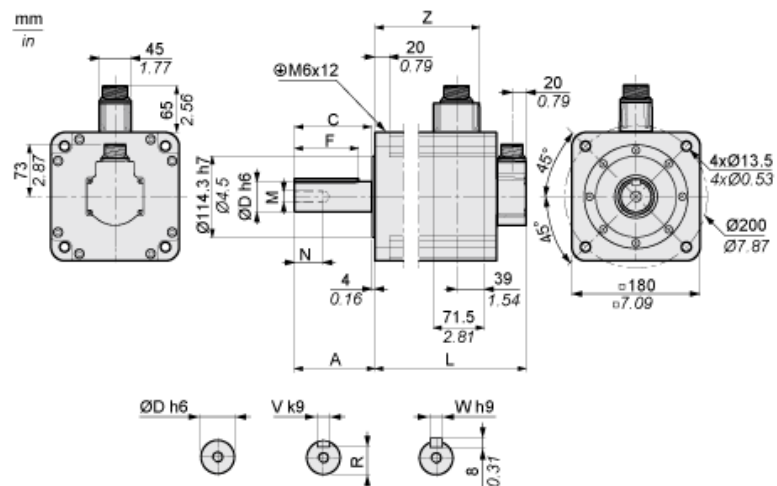

	mm	in.
L (without holding brake)	202	7.95
L (with holding brake)	235	9.25
A	79	3.11
C	73	2.87
D	35	1.38
F	63	2.48
N	28	1.10
M	M12	
R	30	1.18
V	10	0.39
W	10	0.39
Z	136	5.35

Torque/Speed Curves with 230 V Single/Three Phase Supply Voltage

Servo Motor with LXM28AU45••• Servo Drive

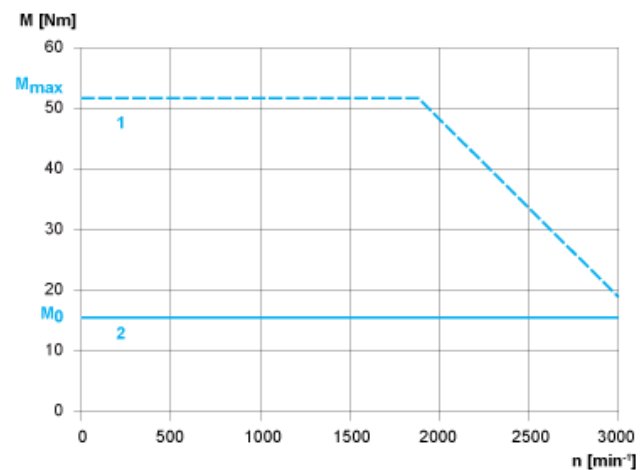

- 1: Peak torque
- 2: Continuous torque