



Main

Range compatibility	Lexium SD3
Product or component type	Motion control motor
Device short name	BRS3
Maximum mechanical speed	3000 rpm
Motor type	3-phase stepper motor
Number of motor poles	6
Supply voltage limits	34 V DC 48 V DC
Mounting support	Flange
Motor flange size	57.2 mm
Length	79 mm
Centring collar diameter	38 mm

Complementary

Centring collar depth	1.6 mm
Number of mounting holes	4
Mounting holes diameter	5.2 mm
Circle diameter of the mounting holes	66.6 mm
Electrical connection	Terminal box
Holding brake	Without
Shaft end	Smooth shaft
Second shaft	Without second shaft end
Shaft diameter	6.35 mm
Shaft length	21 mm
Nominal torque	0.45 N.m
Holding torque	0.51 N.m
Rotor inertia	0.1 kg.cm ²
Resolution	1.8 °, 0.9 °, 0.72 °, 0.36 °, 0.18 °, 0.09 °, 0.072 °, 0.036 ° step angle 200, 400, 500, 1000, 2000, 4000, 5000, 10000 steps number of full steps per revolution
Accuracy error	+/- 6 arc min
Maximum starting frequency	8.5 kHz
[In] rated current	5.2 A
Resistance	0.42 Ohm (winding)
Time constant	2.1 ms
Maximum radial force Fr	25 N (second shaft end) 24 N (first shaft end)
Maximum axial force Fa	100 N (tensile force) 8.4 N (force pressure)
Service life in hours	20000 h (bearing)
Angular acceleration	200000 rad/s ²
Net weight	1.3 kg

The information provided in this documentation contains general descriptions and/or technical characteristics of the performance of the products contained herein. This documentation is not intended as a substitute for and is not to be used for determining suitability or reliability of these products for specific user applications. It is the duty of any such user or integrator to perform the appropriate and complete risk analysis, evaluation and testing of the products with respect to the relevant specific application or use thereof. Neither Schneider Electric Industries SAS nor any of its affiliates or subsidiaries shall be responsible or liable for misuse of the information contained herein.

Environment

Standards	EN 50347 IEC 60072-1
Type of cooling	Natural convection
Ambient air temperature for operation	-25...40 °C
Ambient air temperature for storage	-25...70 °C
Operating altitude	<= 1000 m without power derating
Relative humidity	15...85 % without condensation
Vibration resistance	20 m/s ² maximum A conforming to EN/IEC 60034-14
IP degree of protection	IP56 total except shaft bushing: conforming to EN/IEC 60034-5 IP41 shaft bushing without shaft seal ring: conforming to EN/IEC 60034-5
Temperature class	F winding conforming to IEC/EN 60034-1

Packing Units

Unit Type of Package 1	PCE
Number of Units in Package 1	1
Package 1 Height	10.0 cm
Package 1 Width	16.0 cm
Package 1 Length	21.5 cm
Package 1 Weight	710.0 g

Offer Sustainability

Sustainable offer status	Green Premium product
REACH Regulation	REACH Declaration
EU RoHS Directive	Pro-active compliance (Product out of EU RoHS legal scope)
Mercury free	Yes
China RoHS Regulation	China RoHS Declaration
RoHS exemption information	Yes
Environmental Disclosure	Product Environmental Profile
Circularity Profile	No need of specific recycling operations
WEEE	The product must be disposed on European Union markets following specific waste collection and never end up in rubbish bins
PVC free	Yes

Contractual warranty

Warranty	18 months
----------	-----------

Dimensions

3-Phase Stepper Motor in Terminal Box Version

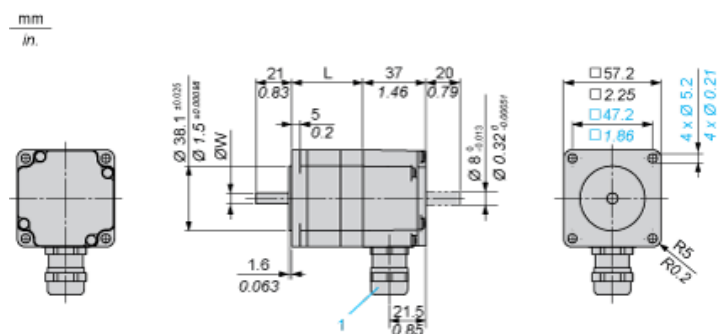

1 : Cable gland M20 x 1.5 for cable Ø 9 ... 13 mm / 0.35 ... 0.51 in.

Dimensions in mm

L	Shaft diameter ØW
42 ±0.5	6.35 ±0.013

Dimensions in in.

L	Shaft diameter ØW
1.65 ±0.020	0.25 ±0.00051

Torque Characteristics

Measurement at 1000 Steps/Revolution, Nominal Voltage DC Bus U_N and Phase Current I_N

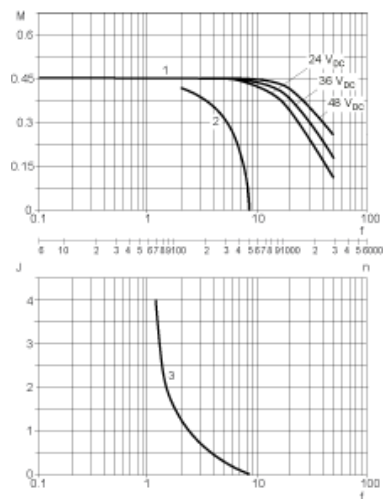

- M : Torque in Nm
- n : Speed in rpm
- f : Frequency in kHz
- J : Rotor inertia in kg.cm²
- 1 : Pull-out torque
- 2 : Pull-in torque
- 3 : Maximum load inertia