



### Main

Range compatibility	Lexium 32i Lexium 32 Lexium 62 ILM Lexium 52 Lexium 62
Gear box type	Straight teeth
Product or component type	Angular planetary gearbox
Device short name	GBY
Product compatibility	BMI (100 mm, 3 motor stacks) BMH (100 mm, 3 motor stacks) BSH (100 mm, 3 motor stacks) BMH (140 mm, 1 motor stacks) BSH (140 mm, 1 motor stacks) SH3 MH3 ILM
Gearbox external diameter	120 mm
Reduction ratio	12:1

### Complementary

Maximum torsional backlash	13 arc.min
Torsional rigidity	13 N.m/arcmin
Housing colour	Black
Housing material	Black anodized aluminium
Shaft material	C 45
Additional information	Lubricated for life
Service life in hours	30000 h at 100 rpm at 30 °C
Mounting position	Any position
Efficiency	92 %
Maximum radial force Fr	1500 N at 100 rpm, force applied at mid-distance from output shaft during 30000 hour at 30 °C
Maximum axial force Fa	2100 N at 100 rpm, during 30000 hour at 30°C
Moment of inertia	5.6 kg.cm <sup>2</sup>
Continuous output torque	260 N.m at 100 rpm at 30 °C
Maximum output torque	416 N.m at 100 rpm at 30 °C
Net weight	14 kg
Input diameter	24.0 mm

### Environment

Noise level	75 dB at 1 m, no-load
IP degree of protection	Shaft output: IP54
Ambient temperature for operation	-25...90 °C

The information provided in this documentation contains general descriptions and/or technical characteristics of the performance of the products contained herein. This documentation is not intended as a substitute for and is not to be used for determining suitability or reliability of these products for specific user applications. It is the duty of any such user or integrator to perform the appropriate and complete risk analysis, evaluation and testing of the products with respect to the relevant specific application or use thereof. Neither Schneider Electric Industries SAS nor any of its affiliates or subsidiaries shall be responsible or liable for misuse of the information contained herein.

## Packing Units

Unit Type of Package 1	PCE
Number of Units in Package 1	1
Package 1 Height	24.0 cm
Package 1 Width	23.0 cm
Package 1 Length	31.5 cm
Package 1 Weight	11.794 kg
Unit Type of Package 2	S06
Number of Units in Package 2	5
Package 2 Height	73.5 cm
Package 2 Width	60.0 cm
Package 2 Length	80.0 cm
Package 2 Weight	71.37 kg

## Offer Sustainability

Sustainable offer status	Green Premium product
REACH Regulation	<a href="#">REACH Declaration</a>
EU RoHS Directive	Pro-active compliance (Product out of EU RoHS legal scope)
Mercury free	Yes
China RoHS Regulation	<a href="#">China RoHS Declaration</a>
RoHS exemption information	<a href="#">Yes</a>
Environmental Disclosure	<a href="#">Product Environmental Profile</a>
Circularity Profile	No need of specific recycling operations
PVC free	Yes

## Contractual warranty

Warranty	18 months
----------	-----------

Dimensions with Servo Motor Adaptation Kit

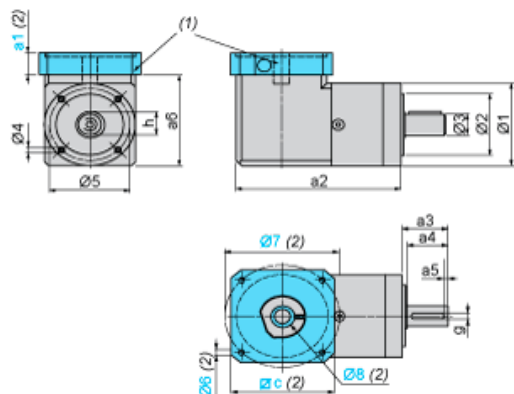

- (1) GBK adaptation kit  
 (2) GBK adaptation kit related dimensions a1, c, Ø6, Ø7, Ø8 depend on the gearbox and servo motor combination  
 Ø8 shaft end adaptor in case motor shaft diameter is smaller than gearbox input coupling diameter

Values in mm

a2	a3	a4	a5	h	g	Ø1	Ø2	Ø3	Ø4	Ø5	a6
221.5	55	50	5	28	8	115	80 h7	25 h7	M10 x 16	100	123.7

Values in in.

a2	a3	a4	a5	h	g	Ø1	Ø2	Ø3	Ø4	Ø5	a6
8.72	2.17	1.97	0.197	1.10	0.31	4.53	3.15 h7	0.98 h7	M10 x 0.63	3.94	4.87