

HMIDM6700WC

15w Display module, Harmony P6, FWXGA, 16M colors, PCAP Multi Touch (2 points) with optimized noise filter



Main

Range of product	Harmony P6
Product or component type	Touch panel screen
Terminal type	Touchscreen display

Complementary

Device mounting	Panel mounting Direct mounting VESA
Pixel resolution	1366 x 768
Display resolution	1366 x 768 pixels FWXGA
Display size	15.6 inch
Aspect ratio	16:9
Display type	LED not replaceable Colour TFT LCD
Display colour	16 million colours
Backlight lifespan	50000 hours at 25 °C
Function available	Standard mode Glove mode Water detection mode
Inrush current	30 A
Power consumption in W	74 W (typical) with advanced box 139 W (maximum) with advanced box 52 W (typical) with standard box 70 W (maximum) with standard box
Touch panel	Multi-touch projected capacitive technology (PCT) with optimized noise filter
Type of installation	Indoor installation
Cut-out dimensions	394 (+ 1/- 0) x 250 (+ 1/- 0) mm
Width	408 mm
Height	264 mm
Depth	Enclosure : 30 mm
Net weight	4.0 kg

The information provided in this documentation contains general descriptions and/or technical characteristics of the performance of the products contained herein. This documentation is not intended as a substitute for and is not to be used for determining suitability or reliability of these products for specific user applications. It is the duty of any such user or integrator to perform the appropriate and complete risk analysis, evaluation and testing of the products with respect to the relevant specific application or use thereof. Neither Schneider Electric Industries SAS nor any of its affiliates or subsidiaries shall be responsible or liable for misuse of the information contained herein.

Environment

IP degree of protection	IP66f IP67f Type 1 Type 4X indoor use Type 12 Type 13
Standards	CE FCC part 15 UL 61010-2-201 CSA C22.2 No 61010-2-201
Product certifications	RCM[RETURN]KC[RETURN]UKCA[RETURN]DNV (DC model without HDD/fan/ EtherCAT card/22" wide display with expansion slot)[RETURN]ATEX zone 22 dust (DC model, front USB cover must be locked with screw)[RETURN]ATEX zone 2 (DC model, front USB cover must be locked with screw)[RETURN]CULus Class 1 Division 2 (without DIO option)[RETURN]IECEX zone 2 (DC model, front USB cover must be locked with screw)[RETURN]IECEX zone 22 (DC model, front USB cover must be locked with screw)
Ambient air temperature for operation	0...60 °C
Ambient air temperature for storage	-20...60 °C
Pollution degree	2
Relative humidity	10...90 % without condensation
Storage Relative Humidity	10...90 % without condensation
Operating altitude	2000 m
Vibration resistance	1 gn (f = 5...9 Hz) single amplitude conforming to IEC 61131-2 1 gn (f = 9...150 Hz) fixed amplitude conforming to IEC 61131-2 1 gn X, Y, Z directions for 10 cycles (approx. 100 min) conforming to IEC 61131-2
Shock resistance	147 m/s ² conforming to IEC 61131-2 147 m/s ² 3 shocks in each direction X, Y and Z
Electromagnetic compatibility	Electrostatic discharge immunity test - test level: 6 kV (contact discharge) conforming to IEC 61000-4-2 level 3 Electrostatic discharge immunity test - test level: 8 kV (air discharge) conforming to IEC 61000-4-2 level 3 Electrical fast transient/burst immunity test - test level: 2 kV (power ports) conforming to IEC 61000-4-4 Electrical fast transient/burst immunity test - test level: 1 kV (signal ports) conforming to IEC 61000-4-4
Type of cooling	Natural
Environmental characteristic	Dust resistant 0.1 mg/m ³ (non-conductive) Corrosive gas free

Packing Units

Unit Type of Package 1	PCE
Number of Units in Package 1	1
Package 1 Height	43.0 cm
Package 1 Width	15.0 cm
Package 1 Length	50.0 cm
Package 1 Weight	4.9 kg
Unit Type of Package 2	P12
Number of Units in Package 2	22
Package 2 Height	150.0 cm
Package 2 Width	80.0 cm
Package 2 Length	120.0 cm
Package 2 Weight	117.8 kg

Offer Sustainability

Sustainable offer status	Green Premium product
REACH Regulation	 REACH Declaration
REACH free of SVHC	Yes
EU RoHS Directive	Pro-active compliance (Product out of EU RoHS legal scope)
Mercury free	Yes

China RoHS Regulation	China RoHS Declaration
RoHS exemption information	Yes
Environmental Disclosure	Product Environmental Profile
Circularity Profile	End Of Life Information

Dimensions

15-inch Wide Advanced Model

External Dimensions

$\frac{\text{mm}}{\text{in.}}$



(C)

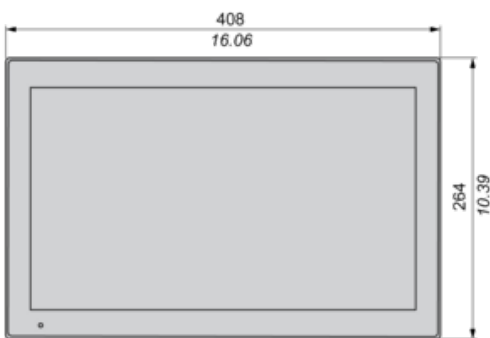

(A)

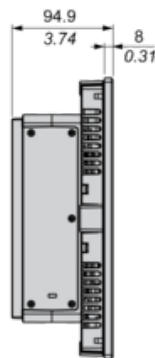

(B)

- (A) : Front
- (B) : Left
- (C) : Bottom

External Dimensions with PCI/PCIe Slots and FAN kit

$\frac{\text{mm}}{\text{in.}}$

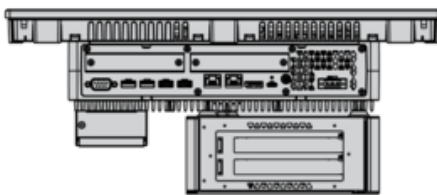

(C)

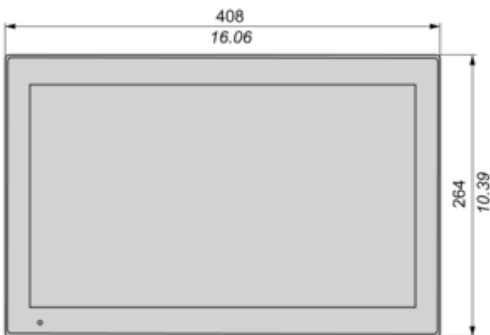

(A)

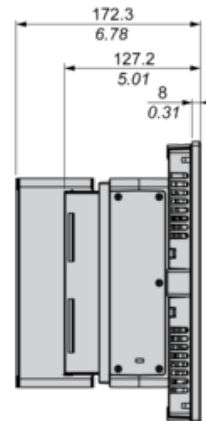

(B)

- (A) : Front
- (B) : Left
- (C) : Bottom

15-inch Wide Standard Model

External Dimensions

mm
in.

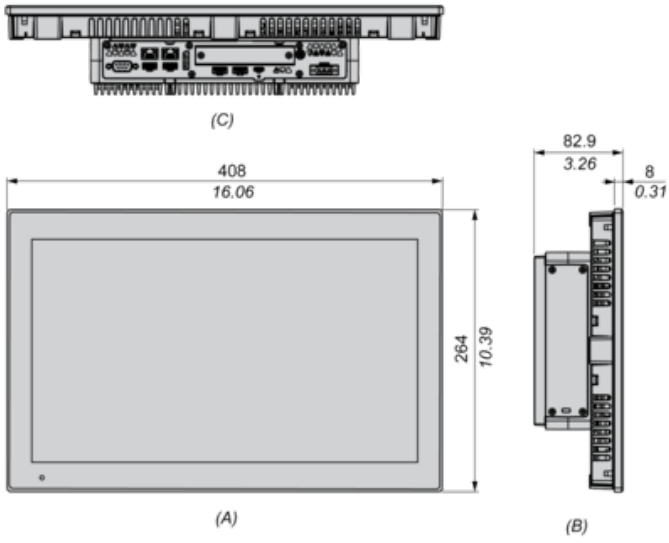

(A) : Front

(B) : Left

(C) : Bottom

Mounting

Panel Cut Dimensions

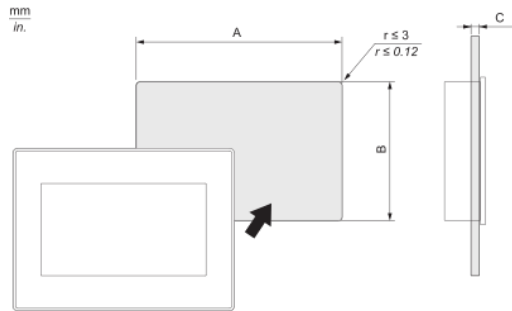

A		B		C	
mm	in.	mm	in.	mm	in.
394 (+1, -0)	15.51 (+0.04, -0)	250 (+1, -0)	9.84 (+0.04, -0)	1.6...5	0.06...0.2

Mounting Angle

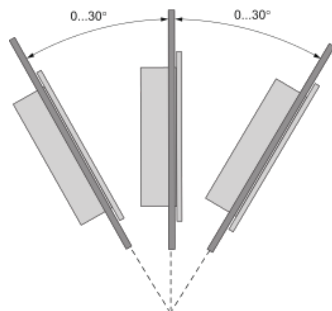

When installing this product in a slanted position, the product face should not incline more than 30°.

Clearance

