

Product data sheet

Characteristics

KTB0230BC01

Cable box, Canalis KTA 800A/1250A, Canalis KTC 1000A/1600A, for straight feed unit, height 230mm

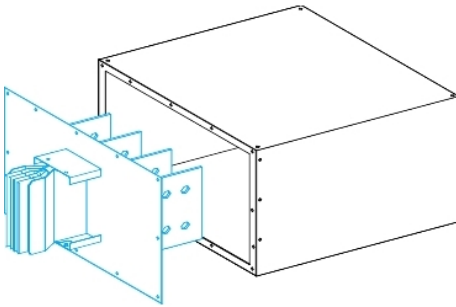

Main

Range	Canalis
Product name	KT
Product or component type	Cable box
Device short name	KTB
Accessory / separate part category	Protection accessory

Complementary

Width	545 mm
Depth	500 mm
Height	230 mm
Net weight	15 kg

Packing Units

Unit Type of Package 1	PCE
Number of Units in Package 1	1
Package 1 Height	232 cm
Package 1 Width	63 cm
Package 1 Length	52 cm
Package 1 Weight	1 kg

Offer Sustainability

Sustainable offer status	Green Premium product
REACH Regulation	REACH Declaration
REACH free of SVHC	Yes
EU RoHS Directive	Compliant EU RoHS Declaration
Toxic heavy metal free	Yes
Mercury free	Yes
China RoHS Regulation	China RoHS Declaration
RoHS exemption information	Yes
Environmental Disclosure	Product Environmental Profile
Circularity Profile	End Of Life Information
WEEE	The product must be disposed on European Union markets following specific waste collection and never end up in rubbish bins

The information provided in this documentation contains general descriptions and/or technical characteristics of the products of the performance of the products contained herein. This documentation is not intended as a substitute for and is not to be used for determining suitability or reliability of these products for specific user applications. It is the duty of any such user or integrator to perform the appropriate and complete risk analysis, evaluation and testing of the products with respect to the relevant specific application or use thereof. Neither Schneider Electric Industries SAS nor any of its affiliates or subsidiaries shall be responsible or liable for misuse of the information contained herein.