



Main

Range of product	Lexium 28
Device short name	LXM28E
Product or component type	Motion servo drive
Format of the drive	Compact housing
Line current	10 A 166.6 % at 220 V, single phase 10 A 144.8 % at 220 V, three phase

Complementary

Network number of phases	Single phase Three phase
[Us] rated supply voltage	200...240 V (- 10...15 %) for three phase 200...240 V (- 20...15 %) for single phase
Supply voltage limits	200...255 V three phase 170...255 V single phase
Supply frequency	50/60 Hz - 5...5 %
Network frequency	47.5...63 Hz
EMC filter	Without EMC filter
Continuous output current	7 A at 16 kHz
Output current 3s peak	21 A at 220 V
Continuous power	1500 W at 220 V
Nominal power	1.5 kW at 220 V 16 kHz
Switching frequency	16 kHz
Overvoltage category	III
Maximum leakage current	4.5 mA
Output voltage	<= power supply voltage
Electrical isolation	Between power and control
Type of cable	Shielded motor cable (temperature: 0...55 °C) copper
Electrical connection	Spring terminal, clamping capacity: 1.3...1.5 mm ² , AWG 16 (L1-L2) Spring terminal, clamping capacity: 1.3...1.5 mm ² , AWG 16 (R, S, T) Spring terminal, clamping capacity: 1.3...1.5 mm ² , AWG 16 (U, V, W, PE) Spring terminal, clamping capacity: 1.3...1.5 mm ² , AWG 16 (PA/+, PBe)
Discrete input number	8 programmable (CN1) 2 fast capture (CN1) 1 safety function STO (CN9)
Discrete input voltage	24 V DC for logic
Discrete input logic	Positive or negative (CN1)
Discrete output number	5 logic output (CN1) at 12...24 V DC 1 pulse train output (PTO) (CN1)
Discrete output voltage	12...24 V DC
Discrete output logic	Positive or negative (CN1)
Control signal type	Servo motor encoder feedback CN2

The information provided in this documentation contains general descriptions and/or technical characteristics of the performance of the products contained herein. This documentation is not intended as a substitute for and is not to be used for determining suitability or reliability of these products for specific user applications. It is the duty of any such user or integrator to perform the appropriate and complete risk analysis, evaluation and testing of the products with respect to the relevant specific application or use thereof. Neither Schneider Electric Industries SAS nor any of its affiliates or subsidiaries shall be responsible or liable for misuse of the information contained herein.

Protection type	Against reverse polarity: inputs signal Against short-circuits: outputs signal Overcurrent: motor Overvoltage: motor Undervoltage: motor Overheating: motor Overload: motor Overspeed: motor
Safety function	STO (safe torque off), integrated
Safety level	SIL 2 conforming to IEC 61800-5-2: 2007 SIL 2 conforming to IEC 61508-1: 2010 PL d/category 3 conforming to ISO 13849-1: 2008 SIL 2 conforming to ISO 13849-1: 2009/AC SIL 2 conforming to IEC 60204-1: 2006 SIL 2 conforming to IEC 60204-1: 2009/A1 SIL 2 conforming to IEC 60204-1: 2010/AC SIL 2 conforming to IEC 62061: 2012
Communication interface	EtherCAT, integrated
Connector type	RJ45 (CN4) for EtherCAT
Method of access	Slave
Transmission rate	100 Mbit/s for EtherCAT
Physical interface	RS485 for Modbus Serial line slave
Status LED	1 LED (red) DC bus energized 1 LED (multi-colour) N.RUN 1 LED (multi-colour) N.ERR 2 LEDs (yellow) Link (Link Status) 2 LEDs (yellow) activity
Signalling function	Servo status and fault codes five 7-segment display units
Marking	CULus CSA CE
Type of cooling	Natural convection
Operating position	Vertical
Product compatibility	Servo motor BCH2 (130 mm, 3 motor stacks) at 1500 W
Width	55 mm
Height	150 mm
Depth	170 mm
Net weight	1.2 kg
Output current 3s peak 2	21 A at 220 V
Output current 3s peak 3	21 A at 220 V

Environment

Electromagnetic compatibility	Conducted emission - test level: level 3 category C3 conforming to IEC 61800-3
Standards	IEC 61800-5-1
Product certifications	cULus[RETURN]CE[RETURN]CSA
IP degree of protection	IP20
Vibration resistance	3M4 amplitude = 3 mm (f = 9...200 Hz) conforming to IEC 60721-3-3
Shock resistance	10 gn, type I conforming to IEC 60721-3-3
Relative humidity	5...95 % without condensation
Ambient air temperature for operation	0...55 °C
Ambient air temperature for storage	-25...65 °C
Operating altitude	<= 1000 m without derating > 1000...2000 m 1 % per 100 m

Packing Units

Unit Type of Package 1	PCE
Number of Units in Package 1	1
Package 1 Height	23.0 cm
Package 1 Width	23.7 cm
Package 1 Length	7.5 cm
Package 1 Weight	1.43 kg
Unit Type of Package 2	S03

Number of Units in Package 2	5
Package 2 Height	30.0 cm
Package 2 Width	30.0 cm
Package 2 Length	40.0 cm
Package 2 Weight	7.74 kg

Offer Sustainability

Sustainable offer status	Green Premium product
REACH Regulation	REACH Declaration
REACH free of SVHC	Yes
EU RoHS Directive	Pro-active compliance (Product out of EU RoHS legal scope)
Mercury free	Yes
China RoHS Regulation	China RoHS Declaration
RoHS exemption information	Yes
Environmental Disclosure	Product Environmental Profile
Circularity Profile	End Of Life Information
WEEE	The product must be disposed on European Union markets following specific waste collection and never end up in rubbish bins
PVC free	Yes

Dimensions

Dimensions of Drive

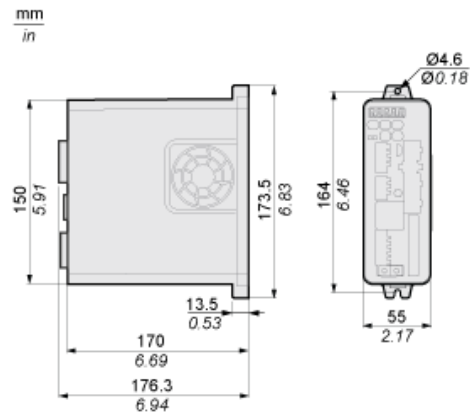

Mounting Clearance

Mounting Distances and Air Circulation

mm
in.

