



## Main

Range compatibility	PacDrive 3
Device short name	SH3.....P
Product or component type	Servo motor

## Complementary

Maximum mechanical speed	6000 rpm
[Us] rated supply voltage	115...480 V
Network number of phases	Three phase
Continuous stall current	6.2 A
Continuous stall torque	10 N.m at 115...480 V three phase
Continuous power	2500 W
Peak stall torque	40.5 N.m at 115...480 V three phase
Nominal output power	1490 W at 230 V single phase 2480 W at 400 V three phase 2480 W at 480 V three phase
Nominal torque	9.5 N.M at 230 V single phase 7.9 N.M at 400 V three phase 6.9 N.m at 480 V three phase
Nominal speed	1500 rpm at 230 V single phase 3000 rpm at 400 V three phase 3600 rpm at 480 V three phase
Maximum current Irms	32.3 A
Shaft end	Smooth shaft
Shaft diameter	24 mm
Shaft length	50 mm
IP degree of protection	IP65 motor: conforming to EN/IEC 60034-5 IP65 shaft bushing: conforming to EN/IEC 60034-5
Encoder type	Absolute multiturn Hiperface DSL
Speed feedback resolution	262144 points/turn x 4096 turns
Holding brake	With
Holding torque	12 N.m
Mounting support	International standard flange
Motor flange size	100 mm
Electrical connection	Rotatable right angled connector
Torque constant	1.62 N.m/A at 120 °C
Back emf constant	103 V/krpm at 20 °C
Number of motor poles	4
Rotor inertia	5.245 kg.cm <sup>2</sup>
Stator resistance	1.8 Ohm
Stator inductance	13 mH

The information provided in this documentation contains general descriptions and/or technical characteristics of the performance of the products contained herein. This documentation is not intended as a substitute for and is not to be used for determining suitability or reliability of these products for specific user applications. It is the duty of any such user or integrator to perform the appropriate and complete risk analysis, evaluation and testing of the products with respect to the relevant specific application or use thereof. Neither Schneider Electric Industries SAS nor any of its affiliates or subsidiaries shall be responsible or liable for misuse of the information contained herein.

Brake pull-in power	18 W
Type of cooling	Natural convection
Length	307.5 mm
Centring collar diameter	95 mm
Centring collar depth	3.5 mm
Number of mounting holes	4
Mounting holes diameter	9.0 mm
Circle diameter of the mounting holes	115 mm
Net weight	9.8 kg

### Packing Units

Unit Type of Package 1	PCE
Number of Units in Package 1	1
Package 1 Height	26.0 cm
Package 1 Width	20.0 cm
Package 1 Length	59.0 cm
Package 1 Weight	11.1 kg

### Offer Sustainability

Sustainable offer status	Green Premium product
REACH Regulation	<a href="#">REACH Declaration</a>
EU RoHS Directive	Pro-active compliance (Product out of EU RoHS legal scope)
Mercury free	Yes
China RoHS Regulation	<a href="#">China RoHS Declaration</a>
RoHS exemption information	<a href="#">Yes</a>
Environmental Disclosure	<a href="#">Product Environmental Profile</a>
Circularity Profile	No need of specific recycling operations
WEEE	The product must be disposed on European Union markets following specific waste collection and never end up in rubbish bins
PVC free	Yes

Dimensions

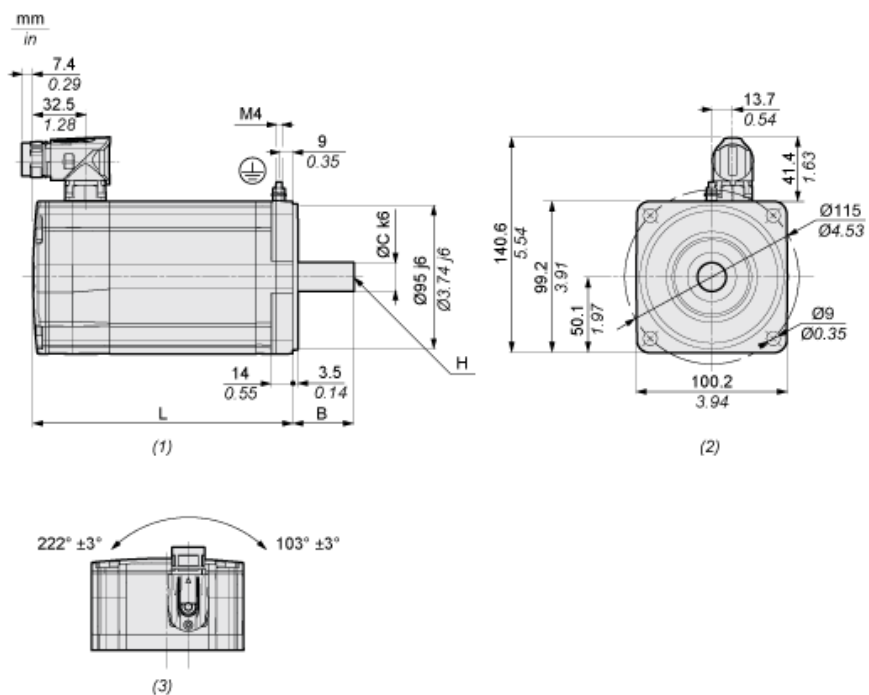

- (1) : Side view
- (2) : Mounting
- (3) : Rotating area

Characteristic	Unit	Value
L	Length with holding brake	mm (in)
B	Shaft length	mm (in)
C	Shaft diameter	mm (in)
H	Female thread of shaft	DIN 332-D M8