



Main

| | |
|---------------------------|-----------------|
| Range of product | Modicon M171 |
| Product or component type | Display module |
| Display colour | Monochrome |
| Supply | External source |

Complementary

| | |
|---------------------------|---------------------------------|
| Display type | LCD screen |
| Number of key | 4 |
| Colour | White |
| [Us] rated supply voltage | 12 V DC |
| Power consumption in W | 5 W 0 W |
| Marking | CE |
| Realtime clock | With clock |
| Local signalling | LCD display |
| Product compatibility | Logic controller M171 optimized |
| Height | 137 mm |
| Width | 96.5 mm |
| Depth | 31.3 mm |
| Net weight | 0.143 kg |

Environment

| | |
|-------------------------|------------------|
| Product certifications | cURus |
| IP degree of protection | IP40 front face: |

Packing Units

| | |
|------------------------------|-----------|
| Unit Type of Package 1 | PCE |
| Number of Units in Package 1 | 1 |
| Package 1 Height | 9.000 cm |
| Package 1 Width | 13.000 cm |
| Package 1 Length | 18.500 cm |
| Package 1 Weight | 259.000 g |
| Unit Type of Package 2 | S02 |
| Number of Units in Package 2 | 6 |
| Package 2 Height | 15.000 cm |
| Package 2 Width | 30.000 cm |
| Package 2 Length | 40.000 cm |
| Package 2 Weight | 1.811 kg |
| Unit Type of Package 3 | P06 |
| Number of Units in Package 3 | 96 |

| | |
|------------------|-----------|
| Package 3 Height | 75.000 cm |
| Package 3 Width | 80.000 cm |
| Package 3 Length | 60.000 cm |
| Package 3 Weight | 36.976 kg |

Offer Sustainability

| | |
|----------------------------|---|
| REACH Regulation | REACH Declaration |
| EU RoHS Directive | Pro-active compliance (Product out of EU RoHS legal scope) |
| Mercury free | Yes |
| China RoHS Regulation | China RoHS Declaration |
| RoHS exemption information | Yes |
| WEEE | The product must be disposed on European Union markets following specific waste collection and never end up in rubbish bins |
| Upgradeability | Upgradeable through digital modules and upgraded components |

Dimensions

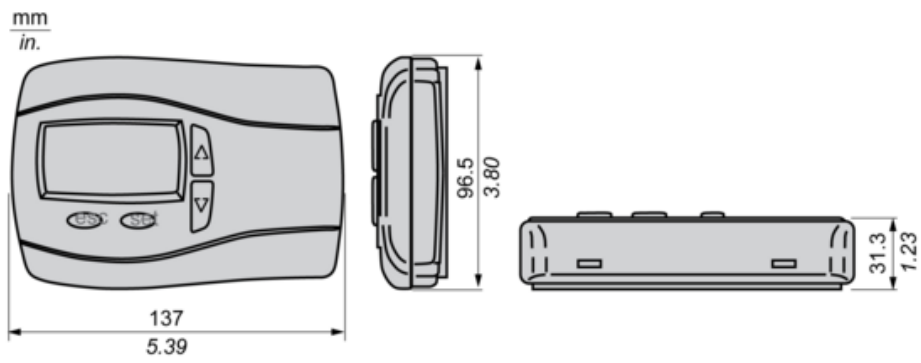

Mounting

mm
in.

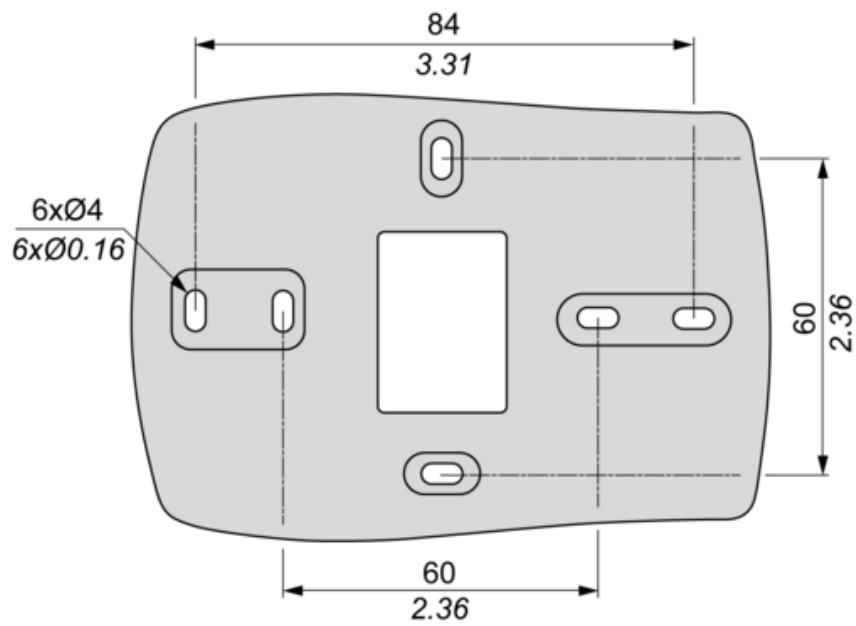

Wiring Diagram

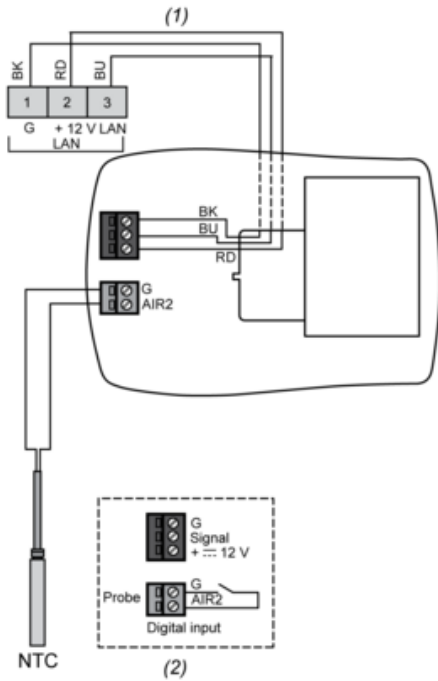

- (1) LAN Expansion bus
- (2) Remote probe not included

RD : Red
BU : Blue
BK : Black

Ex. Transducer

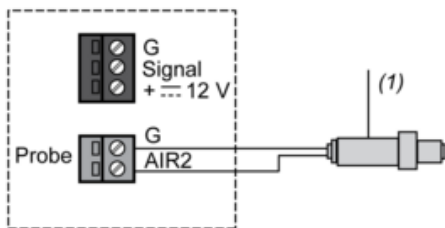

- (1) Power supply