

Main

Range of product	Altivar Lexium
Range compatibility	Lexium 28 Lexium 52 Lexium 05 Lexium 32 Altivar Machine ATV320 Lexium 15 Altivar 32 Lexium 32i Easy Lexium 16
Product compatibility	ATV32HU55N4 ATV32HU75N4 Variable speed drive ATV320 at 5.5 kW, 380...500 V, three phase Variable speed drive ATV320 at 7.5 kW, 380...500 V, three phase Variable speed drive ATV320 at 5.5 kW, 525...600 V, three phase Variable speed drive ATV320 at 7.5 kW, 525...600 V, three phase Motion servo drive LXM16D at 0.75 kW, 200...230 V, single phase Motion servo drive LXM16D at 1 kW, 200...230 V, single phase Motion servo drive LXM16D at 1.5 kW, 200...230 V, single phase
Product or component type	Braking resistor
Ohmic value	27 Ohm

Complementary

Energy peak	10500 J at 480 V 11400 J at 400 V 18100 J at 230 V 25500 J at 115 V
Average power available	100 W at 50 °C
Continuous power	400 W
Protection type	Thermal protection via the servo drive
Net weight	1.42 kg
Cable length	0.75 m

Environment

IP degree of protection	IP65
Ambient air temperature for storage	-25...85 °C
Ambient air temperature for operation	0...50 °C

Packing Units

Unit Type of Package 1	PCE
Number of Units in Package 1	1
Package 1 Height	4.400 cm
Package 1 Width	12.600 cm
Package 1 Length	39.400 cm
Package 1 Weight	1.432 kg
Unit Type of Package 2	S04

Number of Units in Package 2	6
Package 2 Height	30.000 cm
Package 2 Width	40.000 cm
Package 2 Length	60.000 cm
Package 2 Weight	9.475 kg
Unit Type of Package 3	P06
Number of Units in Package 3	24
Package 3 Height	75.000 cm
Package 3 Width	60.000 cm
Package 3 Length	80.000 cm
Package 3 Weight	48.188 kg

Offer Sustainability

REACH Regulation	REACH Declaration
REACH free of SVHC	Yes
EU RoHS Directive	Pro-active compliance (Product out of EU RoHS legal scope)
Mercury free	Yes
China RoHS Regulation	China RoHS Declaration
RoHS exemption information	Yes
PVC free	Yes

Contractual warranty

Warranty	18 months
----------	-----------

Braking Resistor

Dimensions

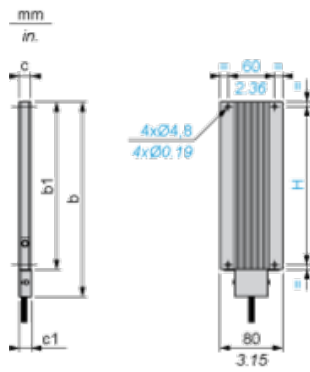

Dimensions in mm

b	b1	c	c1	H
257	216	30	–	204

Dimensions in in.

b	b1	c	c1	H
10.11	8.50	1.18	–	8.03