

XVMM1RAG

Pre assembled and pre cabled indicator bank,
Harmony XVM, without buzzer + 3 illuminated
units, 45mm, 230V AC/DC



Main

Range of product	Harmony XVM
Product or component type	Pre-assembled and pre-cabled indicator bank
Beacon or indicator bank unit type	3 illuminated units
Component name	XVM
Light source	Orange incandescent bulb with BA 15d base steady signalling <5 W Green incandescent bulb with BA 15d base steady signalling <5 W Red incandescent bulb with BA 15d base steady signalling <5 W
Light block color	Red/orange/green
[Us] rated supply voltage	230 V AC/DC
Indicator bank base type	Base without buzzer
Mounting mode	Vertical

Complementary

Kit composition	Base unit Aluminium support tube Cover Plastic fixing plate
Mounting diameter	45 mm
Connections - terminals	Flying leads, clamping capacity: 1 x 0.325 mm ² (AWG 22)
Marking	CE
Mounting support	Aluminium tube
[Ui] rated insulation voltage	250 V conforming to IEC 60947-1
Nominal voltage limit	0.85...1.1 Un conforming to IEC 60947-5-1
[Uimp] rated impulse withstand voltage	4 kV conforming to IEC 60947-1
Net weight	0.493 kg

Environment

IP degree of protection	IP42 vertical position conforming to IEC 60529
Product certifications	CCC
Standards	IEC 60947-1 IEC 60947-5-1
Ambient air temperature for storage	-25...70 °C
Ambient air temperature for operation	-10...50 °C
Overvoltage category	Class I conforming to IEC 60947-1 Class I conforming to IEC 60947-5-1 Class I conforming to IEC 61140
Protective treatment	TC

The information provided in this documentation contains general descriptions and/or technical characteristics of the performance of the products contained herein. This documentation is not intended as a substitute for and is not to be used for determining suitability or reliability of these products for specific user applications. It is the duty of any such user or integrator to perform the appropriate and complete risk analysis, evaluation and testing of the products with respect to the relevant specific application or use thereof. Neither Schneider Electric Industries SAS nor any of its affiliates or subsidiaries shall be responsible or liable for misuse of the information contained herein.

Packing Units

Unit Type of Package 1	PCE
Number of Units in Package 1	1
Package 1 Height	5.500 cm
Package 1 Width	8.300 cm
Package 1 Length	54.000 cm
Package 1 Weight	545.000 g
Unit Type of Package 2	S04
Number of Units in Package 2	20
Package 2 Height	30.000 cm
Package 2 Width	40.000 cm
Package 2 Length	60.000 cm
Package 2 Weight	12.152 kg

Offer Sustainability

Sustainable offer status	Green Premium product
REACH Regulation	REACH Declaration
EU RoHS Directive	Pro-active compliance (Product out of EU RoHS legal scope)
Mercury free	Yes
China RoHS Regulation	China RoHS Declaration
RoHS exemption information	Yes
Environmental Disclosure	Product Environmental Profile
Circularity Profile	No need of specific recycling operations
WEEE	The product must be disposed on European Union markets following specific waste collection and never end up in rubbish bins

Contractual warranty

Warranty	18 months
----------	-----------

Pre-Assembled and Pre-Cabled Tower Light with Fixing Base for Mounting on Vertical Support (Support Tube + Metal Bracket)

Dimensions

Below drawing shows the maximum configuration of the product. Select the number of stages according to the product characteristics in order to get b2 dimension.

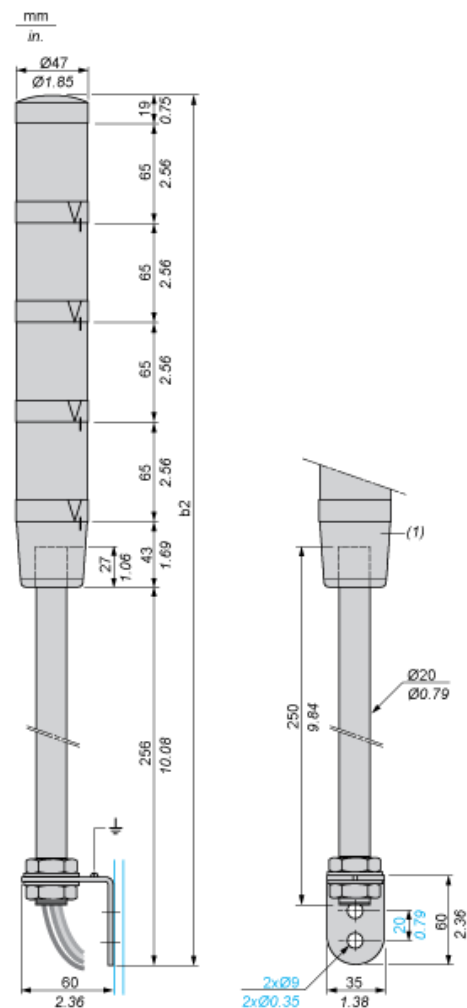

(1) Base unit with or without buzzer.

Number of illuminated units	b2 in mm	b2 in in.
1 unit	383	15.08
2 units	448	17.64
3 units	513	20.20
4 units	578	22.76

Pre-Assembled and Pre-Cabled Tower Light

Wire Colors

4th illuminated unit: yellow wire

3rd illuminated unit: green wire

2nd illuminated unit: white wire

1st illuminated unit: blue wire

Common: black wire

Buzzer (if integrated in base unit): grey wire