



Main

Range of product	Harmony XVM
Accessory / separate part designation	Ø 20 mm aluminium support tube with metal bracket
Product or component type	Support tube
Accessory / separate part category	Mounting and fixing accessories
Accessory / separate part destination	Beacons and indicator banks Ø 45 mm

Complementary

Accessory / separate part type	Support tube with bracket
Product compatibility	XVM.
Colour	Aluminium
Height under base unit	113 mm
Length	100 mm
Net weight	0.198 kg

Packing Units

Unit Type of Package 1	PCE
Number of Units in Package 1	1
Package 1 Height	4.0 cm
Package 1 Width	13.0 cm
Package 1 Length	18.0 cm
Package 1 Weight	202.0 g
Unit Type of Package 2	S02
Number of Units in Package 2	15
Package 2 Height	15.0 cm
Package 2 Width	30.0 cm
Package 2 Length	40.0 cm
Package 2 Weight	3.401 kg
Unit Type of Package 3	PAL
Number of Units in Package 3	240
Package 3 Height	60.0 cm
Package 3 Width	80.0 cm
Package 3 Length	240.0 cm
Package 3 Weight	147.12 kg

The information provided in this documentation contains general descriptions and/or technical characteristics of the products of the performance of the products contained herein. This documentation is not intended as a substitute for and is not to be used for determining suitability or reliability of these products for specific user applications. It is the duty of any such user or integrator to perform the appropriate and complete risk analysis, evaluation and testing of the products with respect to the relevant specific application or use thereof. Neither Schneider Electric Industries SAS nor any of its affiliates or subsidiaries shall be responsible or liable for misuse of the information contained herein.

Offer Sustainability

Sustainable offer status	Green Premium product
REACH Regulation	REACH Declaration
EU RoHS Directive	Pro-active compliance (Product out of EU RoHS legal scope)
Mercury free	Yes
China RoHS Regulation	China RoHS Declaration
RoHS exemption information	Yes
Environmental Disclosure	Product Environmental Profile
Circularity Profile	No need of specific recycling operations

Contractual warranty

Warranty	18 months
----------	-----------

Dimensions and Mounting

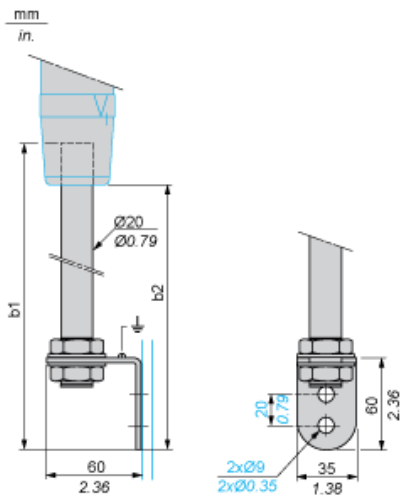

Support tube length		b1 (tube + plate)		b2 (height under base unit)	
mm	in.	mm	in.	mm	in.
100	3.94	133	5.24	106	4.17

Panel Cut-Out

