



Main

| | |
|-------------------------------|--|
| Range of product | Harmony XB5 |
| Product or component type | Complete body/light block assembly |
| Device short name | ZB5 |
| Fixing collar material | Plastic |
| Sale per indivisible quantity | 1 |
| Connections - terminals | Screw clamp terminals, $\leq 2 \times 1.5 \text{ mm}^2$ with cable end conforming to IEC 60947-1 Screw clamp terminals, $\geq 1 \times 0.22 \text{ mm}^2$ without cable end conforming to IEC 60947-1 |
| Light source | Incandescent |
| Bulb base | BA 9s |
| Light block supply | Via integral transformer 1.2 VA 6 V |

Complementary

| | |
|--|---|
| CAD overall width | 30 mm |
| CAD overall height | 42 mm |
| CAD overall depth | 55 mm |
| Terminals description ISO n°1 | (X1-X2)PL |
| Net weight | 0.099 kg |
| Tightening torque | 0.8...1.2 N.m conforming to IEC 60947-1 |
| Shape of screw head | Cross compatible with Philips no 1 screwdriver Cross compatible with pozidriv No 1 screwdriver Slotted compatible with flat $\varnothing 4 \text{ mm}$ screwdriver Slotted compatible with flat $\varnothing 5.5 \text{ mm}$ screwdriver |
| [Ui] rated insulation voltage | 600 V (pollution degree 3) conforming to IEC 60947-1 |
| [Uimp] rated impulse withstand voltage | 6 kV conforming to IEC 60947-1 |
| Signalling type | Steady |
| [Us] rated supply voltage | 440...480 V AC at 50/60 Hz |
| Mounting of block | Front mounting |
| Electrical composition code | P4 M9 |
| Device presentation | Basic sub-assemblies |

Environment

| | |
|---------------------------------------|--|
| Protective treatment | TH |
| Ambient air temperature for storage | -40...70 °C |
| Ambient air temperature for operation | -40...55 °C |
| Electrical shock protection class | Class II conforming to IEC 60536 |
| Standards | IEC 60947-5-1 IEC 60947-5-4 IEC 60947-1 CSA C22.2 No 14 JIS C8201-5-1 UL 508 JIS C8201-1 |
| Product certifications | LROS (Lloyds register of shipping) [RETURN]BV[RETURN]GL[RETURN]CSA[RETURN]DNV[RETURN]JUL listed |

The information provided in this documentation contains general descriptions and/or technical characteristics of the products contained herein. This documentation is not intended as a substitute for and is not to be used for determining suitability or reliability of these products for specific user applications. It is the duty of any such user or integrator to perform the appropriate and complete risk analysis, evaluation and testing of the products with respect to the relevant specific application or use thereof. Neither Schneider Electric Industries SAS nor any of its affiliates or subsidiaries shall be responsible or liable for misuse of the information contained herein.

| | |
|----------------------|--|
| Vibration resistance | 5 gn (f= 2...500 Hz) conforming to IEC 60068-2-6 |
| Shock resistance | 30 gn (duration = 18 ms) for half sine wave acceleration conforming to IEC 60068-2-27 50 gn (duration = 11 ms) for half sine wave acceleration conforming to IEC 60068-2-27 |

Packing Units

| | |
|------------------------------|----------|
| Unit Type of Package 1 | PCE |
| Number of Units in Package 1 | 1 |
| Package 1 Height | 3.6 cm |
| Package 1 Width | 5.5 cm |
| Package 1 Length | 9.2 cm |
| Package 1 Weight | 95.0 g |
| Unit Type of Package 2 | S03 |
| Number of Units in Package 2 | 100 |
| Package 2 Height | 30 cm |
| Package 2 Width | 30 cm |
| Package 2 Length | 40 cm |
| Package 2 Weight | 9.938 kg |

Offer Sustainability

| | |
|----------------------------|---|
| Sustainable offer status | Green Premium product |
| REACH Regulation | REACH Declaration |
| EU RoHS Directive | Pro-active compliance (Product out of EU RoHS legal scope) |
| Mercury free | Yes |
| China RoHS Regulation | China RoHS Declaration |
| RoHS exemption information | Yes |
| WEEE | The product must be disposed on European Union markets following specific waste collection and never end up in rubbish bins |

Contractual warranty

| | |
|----------|-----------|
| Warranty | 18 months |
|----------|-----------|

Dimensions

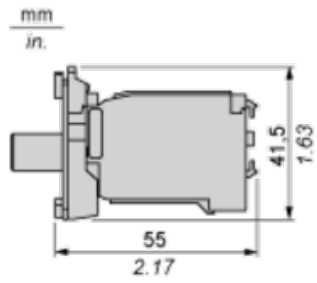

Panel Cut-out for Pushbuttons, Switches and Pilot Lights (Finished Holes, Ready for Installation)

Connection by Screw Clamp Terminals or Plug-in Connectors or on Printed Circuit Board



- (1) Diameter on finished panel or support
- (2) For selector switches and Emergency stop buttons, use of an anti-rotation plate type ZB5AZ902 is recommended.
- (3) $\varnothing 22.5$ mm recommended ($\varnothing 22.3_0^{+0.4}$) / $\varnothing 0.89$ in. recommended ($\varnothing 0.88$ in. $_0^{+0.016}$)

| Connections | a in mm | a in in. | b in mm | b in in. |
|---|---------|----------|---------|----------|
| By screw clamp terminals or plug-in connector | 40 | 1.57 | 30 | 1.18 |
| By Faston connectors | 45 | 1.77 | 32 | 1.26 |
| On printed circuit board | 30 | 1.18 | 30 | 1.18 |

Detail of Lug Recess

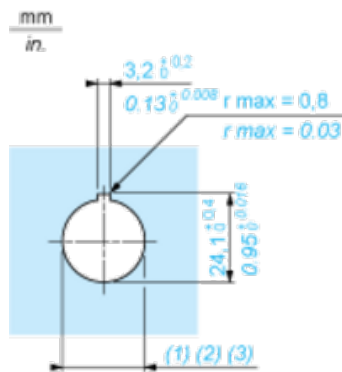

- (1) Diameter on finished panel or support
- (2) For selector switches and Emergency stop buttons, use of an anti-rotation plate type ZB5AZ902 is recommended.
- (3) $\varnothing 22.5$ mm recommended ($\varnothing 22.3_0^{+0.4}$) / $\varnothing 0.89$ in. recommended ($\varnothing 0.88$ in. $_0^{+0.016}$)