



Main

Range of product	Modicon TM3
Product or component type	Discrete input module
Range compatibility	Modicon M241 Modicon M251 Modicon M221 Modicon M262
Discrete input number	16 for input conforming to IEC 61131-2 type 3
Discrete input logic	Sink or source (positive/negative)
Discrete input voltage	24 V
Discrete input current	5 mA for input

Complementary

Discrete I/O number	16
Current consumption	5 mA at 5 V DC via bus connector (at state off) 0 mA at 24 V DC via bus connector (at state on) 0 mA at 24 V DC via bus connector (at state off) 35 mA at 5 V DC via bus connector (at state on)
Discrete input voltage type	DC
Voltage state 1 guaranteed	15...28.8 V for input
Current state 1 guaranteed	≥ 2.5 mA (input)
Voltage state 0 guaranteed	0...5 V for input
Current state 0 guaranteed	≤ 1 mA (input)
Input impedance	4.4 kOhm
Response time	4 ms (turn-on) 4 ms (turn-off)
Local signalling	1 LED per channel (green) for input status
Electrical connection	HE-10 connector for inputs
Maximum cable distance between devices	Unshielded cable: <50 m for regular input
Insulation	Between input and internal logic at 500 V AC Non-insulated between inputs
Marking	CE
Mounting support	Top hat type TH35-15 rail conforming to IEC 60715 Top hat type TH35-7.5 rail conforming to IEC 60715 Plate or panel with fixing kit
Height	90 mm
Depth	81.3 mm
Width	21.4 mm
Net weight	0.65 kg

Environment



Standards	EN/IEC 61010-2-201 EN/IEC 61131-2
Product certifications	CULus C-Tick
Resistance to electrostatic discharge	8 kV in air conforming to EN/IEC 61000-4-2 4 kV on contact conforming to EN/IEC 61000-4-2
Resistance to electromagnetic fields	10 V/m 80 MHz...1 GHz conforming to EN/IEC 61000-4-3 3 V/m 1.4 GHz...2 GHz conforming to EN/IEC 61000-4-3 1 V/m 2 GHz...3 GHz conforming to EN/IEC 61000-4-3
Resistance to magnetic fields	30 A/m 50/60 Hz conforming to EN/IEC 61000-4-8

Resistance to fast transients	1 kV for I/O conforming to EN/IEC 61000-4-4
Surge withstand	1 kV I/O common mode conforming to EN/IEC 61000-4-5 DC
Resistance to conducted disturbances	10 V 0.15...80 MHz conforming to EN/IEC 61000-4-6 3 V spot frequency (2, 3, 4, 6.2, 8.2, 12.6, 16.5, 18.8, 22, 25 MHz) conforming to Marine specification (LR, ABS, DNV, GL)
Electromagnetic emission	Radiated emissions - test level: 40 dB μ V/m QP class A (10 m) at 30...230 MHz conforming to EN/IEC 55011 Radiated emissions - test level: 47 dB μ V/m QP class A (10 m) at 230...1000 MHz conforming to EN/IEC 55011
Ambient air temperature for operation	-10...35 °C vertical installation -10...55 °C horizontal installation
Ambient air temperature for storage	-25...70 °C
Relative humidity	10...95 %, without condensation (in operation) 10...95 %, without condensation (in storage)
IP degree of protection	IP20 with protective cover in place
Pollution degree	2
Operating altitude	0...2000 m
Storage altitude	0...3000 m
Vibration resistance	3.5 mm at 5...8.4 Hz on DIN rail 3 gn at 8.4...150 Hz on DIN rail 3.5 mm at 5...8.4 Hz on panel 3 gn at 8.4...150 Hz on panel
Shock resistance	15 gn for 11 ms

Packing Units

Unit Type of Package 1	PCE
Number of Units in Package 1	1
Package 1 Weight	179 g
Package 1 Height	7.5 cm
Package 1 width	10.5 cm
Package 1 Length	12.5 cm
Unit Type of Package 2	S04
Number of Units in Package 2	42
Package 2 Weight	8.326 kg
Package 2 Height	30 cm
Package 2 width	40 cm
Package 2 Length	60 cm

Offer Sustainability

Sustainable offer status	Green Premium product
REACH Regulation	 REACH Declaration
REACH free of SVHC	Yes
EU RoHS Directive	Pro-active compliance (Product out of EU RoHS legal scope)  EU RoHS Declaration
Toxic heavy metal free	Yes
Mercury free	Yes
RoHS exemption information	 Yes
China RoHS Regulation	 China RoHS Declaration
Environmental Disclosure	 Product Environmental Profile
Circularity Profile	 End Of Life Information
WEEE	The product must be disposed on European Union markets following specific waste collection and never end up in rubbish bins
PVC free	Yes

Dimensions

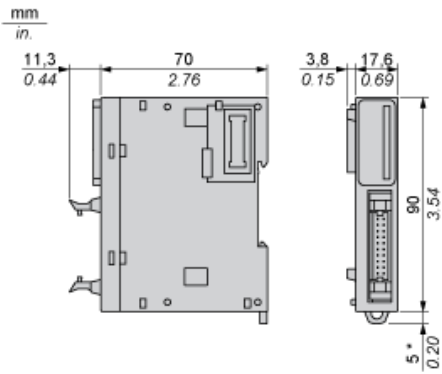

(*) 8.5 mm/0.33 in. when the clamp is pulled out.

Spacing Requirements

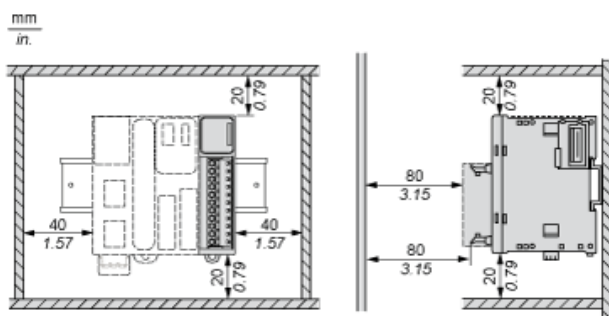

Mounting on a Rail

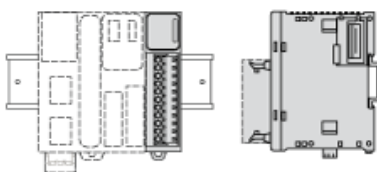

Incorrect Mounting

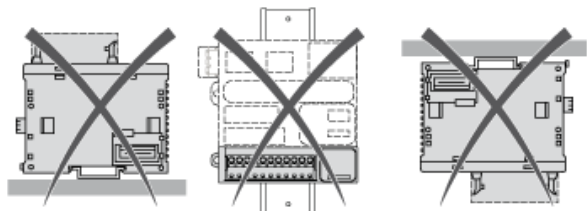

Mounting on a Panel Surface

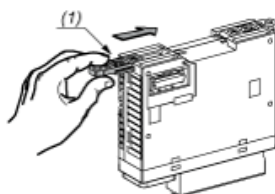

(1) Install a mounting strip

Mounting Hole Layout



Digital Input Module (16-channel, 24 Vdc)

Wiring Diagrams

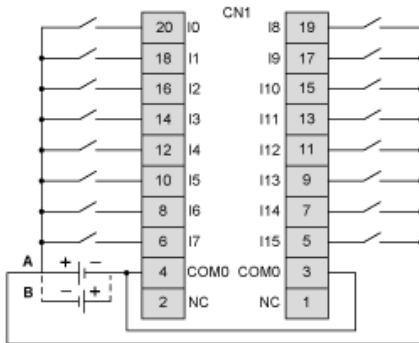

The COM0 terminals are connected internally

- (A) Sink wiring (positive logic)
- (B) Source wiring (negative logic)