



## Main

Range of product	Modicon TM5
Product or component type	Discrete I/O module
Discrete input number	8
Discrete input voltage	24 V
Discrete output number	4
Discrete output type	Transistor

## Complementary

Range compatibility	Modicon M258 Modicon LMC058 PacDrive LMC motion controller
Product compatibility	PacDrive LMC Pro 2 Motion controller PacDrive LMC Pro PacDrive LMC Eco Logic controller
Discrete input voltage type	DC
Input voltage limits	20.4...28.8 V
Discrete input logic	Sink
Discrete input current	3.75 mA
Input impedance	6.4 kOhm
Output voltage	24 V DC
Output voltage limits	20.4...28.8 V
Discrete output logic	Source
Current per channel	0.5 A
Maximum current per output common	2 A
Colour	White
Peak output current	12 A
Switching frequency	<= 500 Hz resistive load
Voltage state 0 guaranteed	<= 5 V
Voltage state 1 guaranteed	>= 15 V
Input filtering	<= 25 ms configurable by software <= 100 ms hardware
Response time	<= 300 µs from state 0 to state 1 for output <= 300 µs from state 1 to state 0 for output
Maximum leakage current	5 µA when switched off
Protection type	Reverse polarity protection Short-circuit protection Overload protection
Isolation	No insulation between channels 500 Vrms AC insulation between channel and bus
Maximum voltage drop	<0.3 V at 500 mA for output
Current consumption	42 mA at 5 V DC bus 21 mA at 24 V DC all inputs On
Maximum power dissipation in W	1.52 W

The information provided in this documentation contains general descriptions and/or technical characteristics of the products of the products contained herein. This documentation is not intended as a substitute for and is not to be used for determining suitability or reliability of these products for specific user applications. It is the duty of any such user or integrator to perform the appropriate and complete risk analysis, evaluation and testing of the products with respect to the relevant specific application or use thereof. Neither Schneider Electric Industries SAS nor any of its affiliates or subsidiaries shall be responsible or liable for misuse of the information contained herein.

Local signalling	1 LED green for power supply 1 LED red for power supply 4 LEDs yellow for output status 8 LEDs green for input status
Electrical connection	1 wire
Marking	CE
Net weight	0.025 kg



## Environment

Standards	CSA C22.2 No 142 UL 508 CSA C22.2 No 213 IEC 61131-2
Product certifications	GOST-R CULus C-Tick CSA
Ambient air temperature for operation	-10...55 °C without derating (horizontal installation) -10...60 °C with derating factor (horizontal installation) -10...50 °C (vertical installation)
Ambient air temperature for storage	-40...70 °C
Relative humidity	5...95 % without condensation
IP degree of protection	IP20 conforming to IEC 61131-2
Pollution degree	2 conforming to IEC 60664
Operating altitude	0...2000 m
Storage altitude	0...3000 m
Vibration resistance	1 gn at 8.4...150 Hz on DIN rail 3.5 mm at 5...8.4 Hz on DIN rail
Shock resistance	15 gn for 11 ms
Electromagnetic compatibility	Electrostatic discharge immunity test, 4 kV on contact conforming to EN/IEC 61000-4-2 Electrostatic discharge immunity test, 8 kV in air conforming to EN/IEC 61000-4-2 Susceptibility to electromagnetic fields, 1 V/m 2...2.7 GHz conforming to EN/IEC 61000-4-3 Susceptibility to electromagnetic fields, 10 V/m 80...2000 MHz conforming to EN/IEC 61000-4-3 Electrical fast transient/burst immunity test, 1 kV I/O conforming to EN/IEC 61000-4-4 Electrical fast transient/burst immunity test, 1 kV shielded cable conforming to EN/IEC 61000-4-4 Electrical fast transient/burst immunity test, 2 kV power lines conforming to EN/IEC 61000-4-4 1.2/50 µs shock waves immunity test, 0.5 kV differential mode conforming to EN/IEC 61000-4-5 1.2/50 µs shock waves immunity test, 1 kV common mode conforming to EN/IEC 61000-4-5 Conducted RF disturbances conforming to EN/IEC 61000-4-6 Conducted and radiated emissions conforming to CISPR 11

## Packing Units

Unit Type of Package 1	PCE
Number of Units in Package 1	1
Package 1 Weight	38 g
Package 1 Height	2 cm
Package 1 width	6 cm
Package 1 Length	11 cm

## Offer Sustainability

Sustainable offer status	Green Premium product
REACH Regulation	 <a href="#">REACH Declaration</a>
REACH free of SVHC	Yes
EU RoHS Directive	Pro-active compliance (Product out of EU RoHS legal scope)  <a href="#">EU RoHS Declaration</a>
Toxic heavy metal free	Yes

Mercury free	Yes
RoHS exemption information	<a href="#">Yes</a>
China RoHS Regulation	<a href="#">China RoHS Declaration</a>
Environmental Disclosure	<a href="#">Product Environmental Profile</a>
Circularity Profile	<a href="#">End Of Life Information</a>
WEEE	The product must be disposed on European Union markets following specific waste collection and never end up in rubbish bins
PVC free	Yes

### Contractual warranty

Warranty	18 months
----------	-----------

---

TM5 Slice

---

Dimensions



TM5 System

Spacing Requirements

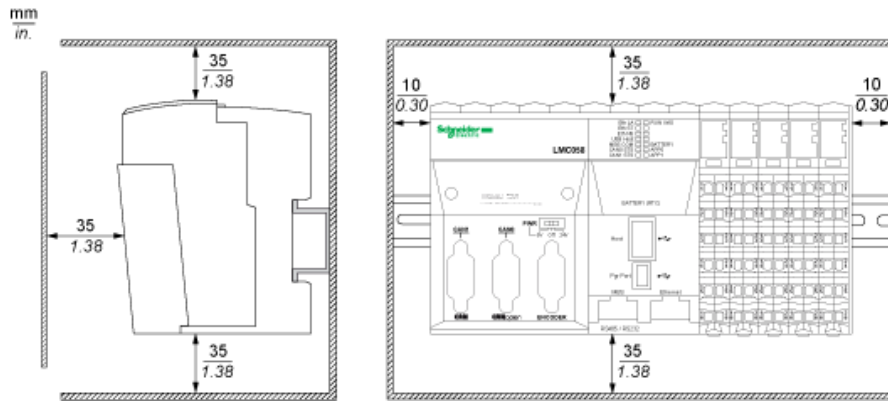

Mounting on a DIN Rail

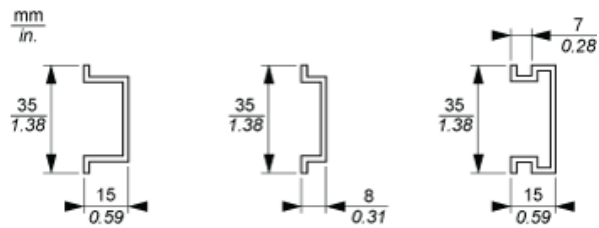

TM5 System Wiring Recommendations

Wire Sizes to Use with the Removable Spring Terminal Blocks

mm in.				
mm <sup>2</sup>	0,08...2,5	0,25...2,5	0,25...1,5	2 x 0,25...2 x 0,75
AWG	28...14	24...14	24...16	2 x 24...2 x 18

Electronic Module 8DI/4DO Tr 1 Wire

Wiring Diagram

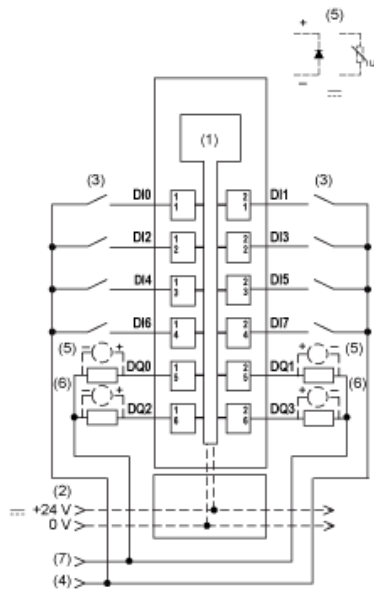

- (1) Internal electronics
- (2) 24 Vdc I/O power segment integrated into the bus bases
- (3) 2-wire sensor
- (4) 24 Vdc I/O power segment by external connection
- (5) Inductive load protection
- (6) 2-wire load
- (7) 0 Vdc I/O power segment by external connection

To connect 2-wire devices, you can add TM5SPDD12F and TM5SPDG12F Common Distribution modules:

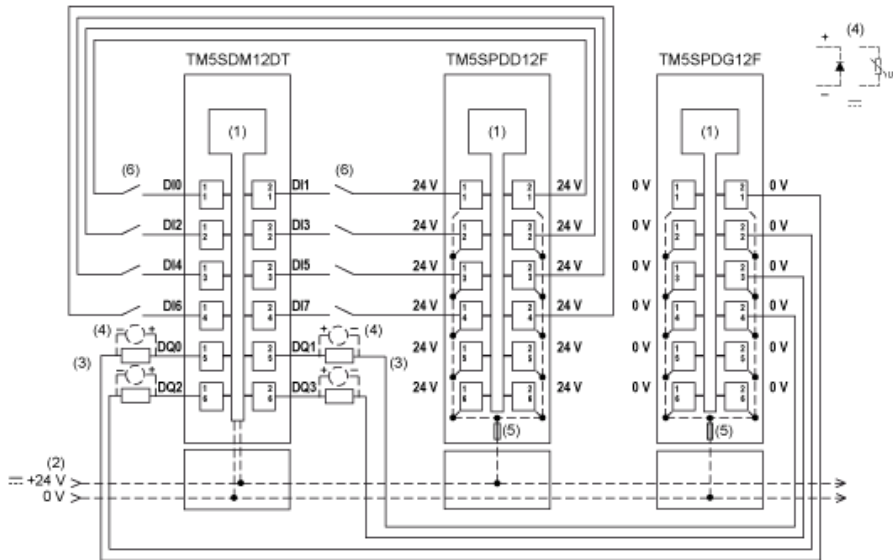

- (1) Internal electronics
- (2) 24 Vdc I/O power segment integrated into the bus bases
- (3) 2-wire load
- (4) Inductive load protection
- (5) Integrated fuse type T slow-blow 6.3 A 250 V exchangeable
- (6) 2-wire sensor