

### Main

Range of product	Canalis
Product name	KS
Offer type	Standard
Product or component type	Elbow
Busbar description	Fire barrier on made to measure
Bar material	Aluminium
Device application	Change direction
[Ie] rated operational current	100 A at 35 °C

### Complementary

[Ue] rated operational voltage	230...690 V
Network frequency	50/60 Hz
Operating angle	90 °
Mounting location	On trunking
Mounting position	Any position
Electrical connection	Lubricated sliding contact
Mounting mode	By screws
Width	147 mm
Depth	46 mm
Height	200...695 mm
Net weight	8.4 kg



### Environment

Standards	IEC 60439-2 IEC 61439-6
-----------	----------------------------

### Packing Units

Unit Type of Package 1	PCE
Number of Units in Package 1	1
Package 1 Weight	15 kg
Package 1 Height	16.7 cm
Package 1 width	72.6 cm
Package 1 Length	93.1 cm

### Offer Sustainability

Sustainable offer status	Green Premium product
REACH Regulation	 REACH Declaration
REACH free of SVHC	Yes
EU RoHS Directive	Compliant  EU RoHS Declaration
Toxic heavy metal free	Yes
Mercury free	Yes
RoHS exemption information	 Yes

China RoHS Regulation	<a href="#">China RoHS Declaration</a>
Environmental Disclosure	<a href="#">Product Environmental Profile</a>
WEEE	The product must be disposed on European Union markets following specific waste collection and never end up in rubbish bins
Halogen content performance	Halogen free product

### Contractual warranty

Warranty	18 months
----------	-----------

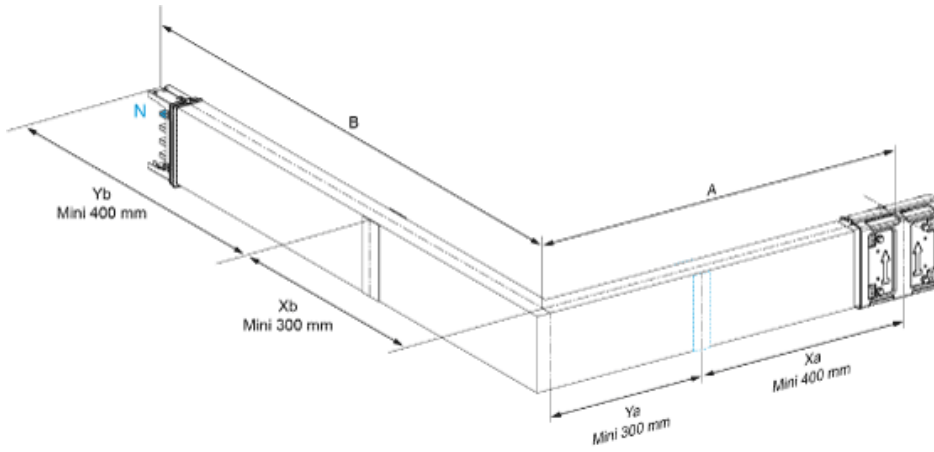

**Dimensions** KSA250DLC4CF

A (mm)	-
B (mm)	-
C (mm)	-
D (mm)	-
Fire barrier	Yes
Fire barrier position	Either on side A or B