



## Main

Range of product	Telemecanique Cabling components
Accessory / separate part category	Cabling accessory
Accessory / separate part type	Pre-wired connectors
Series name	General purpose

## Complementary

Electrical connection	Elbowed female connector M12, 3 pins
Cable connector fixing	Screw-on
Collar material	Metal
Status LED	2 PNP LEDs
Cable length	2 m
Cable outer diameter	5.2 mm
Cable composition	3 x 0.34 mm <sup>2</sup>
Wire insulation material	PUR
[Ue] rated operational voltage	10...30 V DC
[In] rated current	4 A
Contact resistance	5000 µOhm
Minimum insulating resistance	1 GΩ
Net weight	0.08 kg

## Environment

IP degree of protection	IP67 IP69K IP65
Product certifications	CULus
Ambient air temperature for operation	-40...80 °C static -5...80 °C flexing
Ambient air temperature for storage	-40...80 °C

## Packing Units

Unit Type of Package 1	PCE
Number of Units in Package 1	1
Package 1 Weight	62 g
Package 1 Height	3 cm
Package 1 width	24.2 cm
Package 1 Length	27.1 cm
Unit Type of Package 2	BAG
Number of Units in Package 2	1
Package 2 Weight	62 g
Package 2 Height	3 cm

Package 2 width	24.2 cm
Package 2 Length	27.1 cm
Unit Type of Package 3	S02
Number of Units in Package 3	40
Package 3 Weight	2.95 kg
Package 3 Height	15 cm
Package 3 width	30 cm
Package 3 Length	40 cm

### Offer Sustainability

Sustainable offer status	Green Premium product
REACH Regulation	<a href="#">REACH Declaration</a>
EU RoHS Directive	Pro-active compliance (Product out of EU RoHS legal scope) <a href="#">EU RoHS Declaration</a>
Mercury free	Yes
RoHS exemption information	<a href="#">Yes</a>
Environmental Disclosure	<a href="#">Product Environmental Profile</a>
Circularity Profile	<a href="#">End Of Life Information</a>

### Contractual warranty

Warranty	18 months
----------	-----------

Dimensions

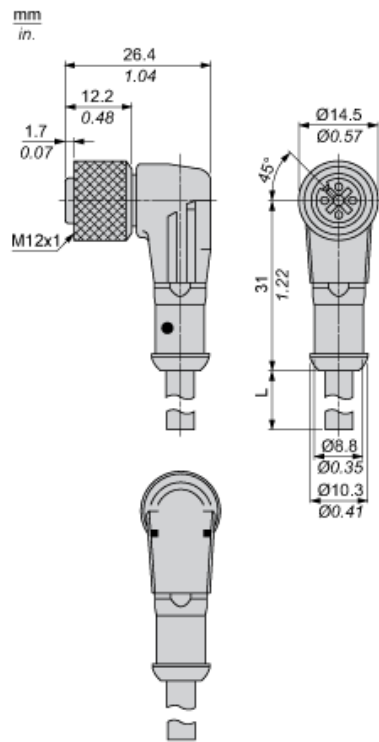

L : Length of cable

---

Connections and Schemes

---

Connector

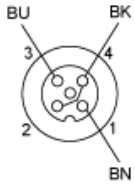

BN : Brown  
BK : Black  
BU : Blue

---

Connections and Schemes

---

LED Connection

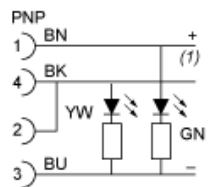

BN : Brown  
BK : Black  
BU : Blue  
GN : Green  
YW : Yellow  
(1) Signal