

XB5S9B2L2

Harmony XB5S, Biometric switch monostable
RGPD, plastic, Ø22, USB, connection by 2m
cable, 24 V AC/DC



Main

Product or component type	Biometric switch RGPD
Product specific application	Materials handling Industrial machines
Device short name	XB5S
Bezel material	Plastic
Mounting diameter	22 mm
Output type	PNP
Sale per indivisible quantity	1
IP degree of protection	IP20 (rear face) conforming to EN/IEC 60529 IP65 (front face) conforming to EN/IEC 60529
Type of operator	Momentary
Operator profile	Fingerprint reader
Connections - terminals	1 pre-wired cable, 3 x 0.11 mm ²
Memory usage	200 users with up to 2 fingerprints per user

Complementary

Software designation	XB5SSoft
Enclosure material	Polyamide PA66
Cable insulation material	PvR
Operating position	Vertical surface installation Flat surface installation Horizontal position
Function of module	Monostable
Net weight	0.202 kg
Marking	CE
Port protocol	USB
Connector type	USB type A male with 1 m cable
Local signalling	1 LED (green) for output state indicator 1 LED (red) for error
Short-circuit protection	250 mA external fuse type gG
[Us] rated supply voltage	24 V DC
Electrical connection	Free wire ends with 3 wires of 2 m
Supply voltage limits	20...30 V DC
Protection type	Reverse polarity Short-circuit Overload protection
Maximum switching current	200 mA
[Ures] residual voltage	1 V closed state
Current consumption	<= 70 mA no-load
Maximum delay first up	3 s + 0.5 ms per user registered
Maximum delay recovery	1.5 s
Maximum delay response	1.5 s

The information provided in this documentation contains general descriptions and/or technical characteristics of the performance of the products contained herein. This documentation is not intended as a substitute for and is not to be used for determining suitability or reliability of these products for specific user applications. It is the duty of any such user or integrator to perform the appropriate and complete risk analysis, evaluation and testing of the products with respect to the relevant specific application or use thereof. Neither Schneider Electric Industries SAS nor any of its affiliates or subsidiaries shall be responsible or liable for misuse of the information contained herein.

Environment

Range of product	Harmony XB5S
Ambient air temperature for storage	-25...70 °C
Ambient air temperature for operation	-5...50 °C
NEMA degree of protection	NEMA 12
Standards	IEC 61000-6-4 IEC 61000-6-2
Product certifications	CSA UL
Vibration resistance	+/- 3 mm (f= 5...9 Hz) conforming to IEC 60068-2-6 1 gn (f= 9...500 Hz) conforming to IEC 60068-2-6
Shock resistance	50 gn 11 ms conforming to IEC 60068-2-27

Packing Units

Unit Type of Package 1	PCE
Number of Units in Package 1	1
Package 1 Weight	193 g
Package 1 Height	6.6 cm
Package 1 width	9.5 cm
Package 1 Length	18.4 cm

Offer Sustainability

EU RoHS Directive	Compliant  EU RoHS Declaration
Mercury free	Yes
RoHS exemption information	 Yes
China RoHS Regulation	 China RoHS Declaration
WEEE	The product must be disposed on European Union markets following specific waste collection and never end up in rubbish bins

Contractual warranty

Warranty	18 months
----------	-----------

Dimensions of Biometric Switches

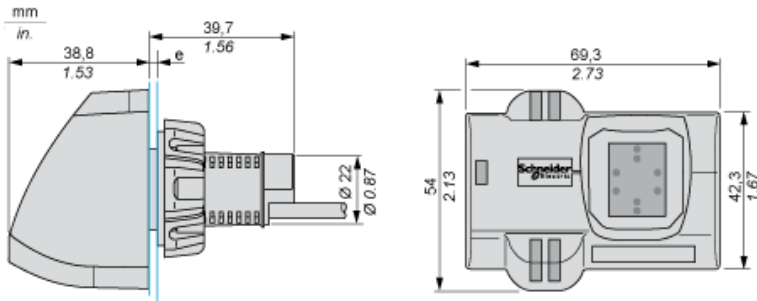

e: 1 to 6 mm / 0.04 to 0.24 in.

Cable with PNP Output

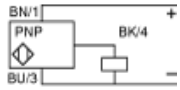

BU: Blue
BN: Brown
BK: Black