



Main

Range of product	Harmony XPE
Product or component type	Foot switch
Material	Plastic
Foot switch type	Single foot switch
Device short name	XPEB
Trigger mechanism	Without trigger mechanism
Contact operation	1 step
Contacts type and composition	1 NC + 1 NO
Colour	Blue

Complementary

Positive opening	With conforming to EN/IEC 60947-5-1 appendix K
Connections - terminals	Screw clamp terminal, $\leq 1 \times 2.5 \text{ mm}^2$ with or without cable end Screw clamp terminal, $\leq 2 \times 1.5 \text{ mm}^2$ with or without cable end
Cable entry	2 plain holes for M20 cable gland
Mechanical durability	10000000 cycles
[Ie] rated operational current	3 A, 240 V, AC-15, A300 0.27 A, 250 V, DC-13, Q300 conforming to EN/IEC 60947-5-1 appendix A
[Ui] rated insulation voltage	500 V (pollution degree 3) conforming to EN/IEC 60947-1 500 V (pollution degree 3) conforming to NF C 20-040 group C 500 V (pollution degree 3) conforming to VDE 0110 group C 300 V conforming to UL 508 300 V conforming to CSA C22.2 No 14
[Uimp] rated impulse withstand voltage	EN/IEC 60947-1 6 kV
Maximum resistance across terminals	25 MOhm conforming to IEC 60255-7 category 3 25 MOhm conforming to NF C 93-050 method A
Short-circuit protection	10 A cartridge fuse type gG conforming to EN/IEC 60947-5-1 10 A cartridge fuse type gG conforming to VDE 0660-200
Rated operational power in W	10 W DC-13, operating rate $<60 \text{ cyc/mn}$, 5000000 cycles, 24 V, load factor: 0.5 conforming to EN/IEC 60947-5-1 appendix C 4 W DC-13, operating rate $<60 \text{ cyc/mn}$, 5000000 cycles, 120 V, load factor: 0.5 conforming to EN/IEC 60947-5-1 appendix C 7 W DC-13, operating rate $<60 \text{ cyc/mn}$, 5000000 cycles, 48 V, load factor: 0.5 conforming to EN/IEC 60947-5-1 appendix C
Net weight	0.57 kg

Environment

Standards	CSA C22.2 No 14 EN/IEC 60947-5-1 UL 508
Product certifications	CSA UL
Protective treatment	TH
Ambient air temperature for operation	-25...70 °C
Ambient air temperature for storage	-40...70 °C
Vibration resistance	5 gn ($f= 10...500 \text{ Hz}$) conforming to IEC 60068-2-6
Shock resistance	30 gn conforming to IEC 60068-2-27
Overvoltage category	Class II conforming to EN/IEC 61140 Class II conforming to NF C 20-030
IP degree of protection	IP66 conforming to IEC 60529

Packing Units

Unit Type of Package 1	PCE
Number of Units in Package 1	1
Package 1 Weight	818 g
Package 1 Height	8.6 cm
Package 1 width	28.4 cm
Package 1 Length	17.2 cm
Unit Type of Package 2	S04
Number of Units in Package 2	12
Package 2 Weight	10.297 kg
Package 2 Height	30 cm
Package 2 width	40 cm
Package 2 Length	60 cm
Unit Type of Package 3	P06
Number of Units in Package 3	48
Package 3 Weight	52.004 kg
Package 3 Height	77 cm
Package 3 width	60 cm
Package 3 Length	80 cm

Offer Sustainability

Sustainable offer status	Green Premium product
REACH Regulation	REACH Declaration
EU RoHS Directive	Pro-active compliance (Product out of EU RoHS legal scope) EU RoHS Declaration
Mercury free	Yes
RoHS exemption information	Yes
China RoHS Regulation	China RoHS Declaration
Environmental Disclosure	Product Environmental Profile
WEEE	The product must be disposed on European Union markets following specific waste collection and never end up in rubbish bins

Contractual warranty

Warranty	18 months
----------	-----------

Plastic Foot Switch without Protective Cover

Dimensions

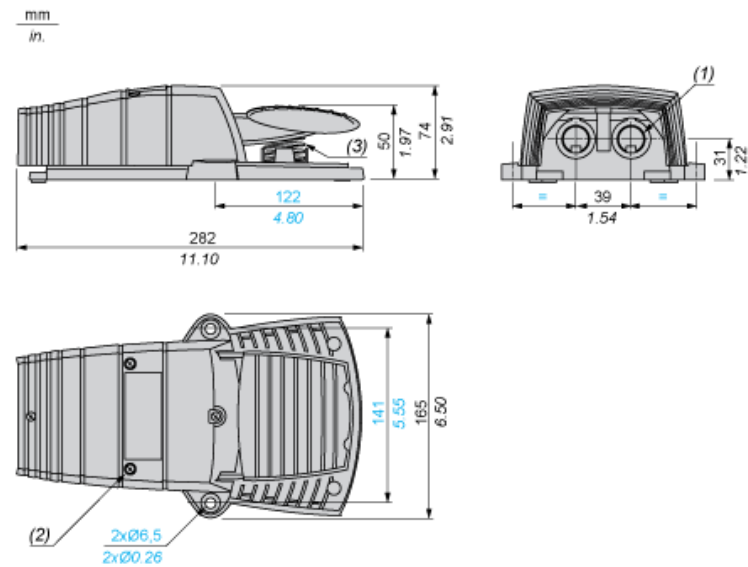

- (1) 2 plain holes for ISO M20 or n° 13 (Pg 13.5) cable gland.
- (2) 4 cover fixing screws: stainless steel. Tightening torque: 1 N.m.
- (3) Return spring: stainless steel.

Electrical Durability of Contacts

AC-15 Utilization Category

Operating rate: 3600 operating cycles/hour. Load factor: 0.5.

Inductive circuit:



X Current in A

Y Millions of operating cycles

DC-13 Utilization Category

Refer to the product characteristic "Operational power in W".