

## Main

Range of product	Harmony XPE
Product or component type	Foot switch
Material	Metal
Foot switch type	Double foot switch
Device short name	XPEM
Provided equipment	Cover
Trigger mechanism	Without trigger mechanism
Contact operation	1 step
Contacts type and composition	2 x 2 NC + 1 NO
Colour	Blue

## Complementary

Positive opening	With conforming to EN/IEC 60947-5-1 appendix K
Connections - terminals	Screw clamp terminal, $\leq 1 \times 2.5 \text{ mm}^2$ with or without cable end Screw clamp terminal, $\leq 2 \times 1.5 \text{ mm}^2$ with or without cable end
Cable entry	2 entries tapped for Pg 16 cable gland
Mechanical durability	15000000 cycles
[Ie] rated operational current	3 A, 240 V, AC-15, A300 0.27 A, 250 V, DC-13, Q300 conforming to EN/IEC 60947-5-1 appendix A
[Ui] rated insulation voltage	500 V (pollution degree 3) conforming to EN/IEC 60947-1 500 V (pollution degree 3) conforming to NF C 20-040 group C 500 V (pollution degree 3) conforming to VDE 0110 group C 300 V conforming to UL 508 300 V conforming to CSA C22.2 No 14
[Uimp] rated impulse withstand voltage	EN/IEC 60947-1 6 kV
Maximum resistance across terminals	25 MOhm conforming to IEC 60255-7 category 3 25 MOhm conforming to NF C 93-050 method A
Short-circuit protection	10 A cartridge fuse type gG conforming to EN/IEC 60947-5-1 10 A cartridge fuse type gG conforming to VDE 0660-200
Rated operational power in W	10 W DC-13, operating rate $<60 \text{ cyc/mn}$ , 5000000 cycles, 24 V, load factor: 0.5 conforming to EN/IEC 60947-5-1 appendix C 4 W DC-13, operating rate $<60 \text{ cyc/mn}$ , 5000000 cycles, 120 V, load factor: 0.5 conforming to EN/IEC 60947-5-1 appendix C 7 W DC-13, operating rate $<60 \text{ cyc/mn}$ , 5000000 cycles, 48 V, load factor: 0.5 conforming to EN/IEC 60947-5-1 appendix C
Physical characteristics	(11-12)NC B (13-14)NO (23-24)NO (21-22)NC
Net weight	5.92 kg

## Environment

Standards	NF E 09-031
Product certifications	CSA FIMKO
Protective treatment	TC
Ambient air temperature for operation	-25...70 °C
Ambient air temperature for storage	-40...70 °C
Vibration resistance	15 gn (f= 10...500 Hz) conforming to IEC 60068-2-6

Shock resistance	150 gn conforming to NF E 09-031 20 gn conforming to IEC 60068-2-27
Overvoltage category	Class I conforming to EN/IEC 61140 Class I conforming to NF C 20-030
IP degree of protection	IP66 conforming to IEC 60529 IP669 conforming to NF C 20-010

## Packing Units

Unit Type of Package 1	PCE
Number of Units in Package 1	1
Package 1 Weight	8.456 kg
Package 1 Height	30.4 cm
Package 1 width	39.6 cm
Package 1 Length	58.6 cm
Unit Type of Package 2	S04
Number of Units in Package 2	1
Package 2 Weight	9.102 kg
Package 2 Height	30 cm
Package 2 width	40 cm
Package 2 Length	60 cm
Unit Type of Package 3	P06
Number of Units in Package 3	4
Package 3 Weight	42.356 kg
Package 3 Height	77 cm
Package 3 width	60 cm
Package 3 Length	80 cm

## Offer Sustainability

Sustainable offer status	Green Premium product
REACH Regulation	<a href="#">REACH Declaration</a>
REACH free of SVHC	Yes
EU RoHS Directive	Pro-active compliance (Product out of EU RoHS legal scope) <a href="#">EU RoHS Declaration</a>
Toxic heavy metal free	Yes
Mercury free	Yes
RoHS exemption information	<a href="#">Yes</a>
China RoHS Regulation	<a href="#">China RoHS Declaration</a>
Environmental Disclosure	<a href="#">Product Environmental Profile</a>
WEEE	The product must be disposed on European Union markets following specific waste collection and never end up in rubbish bins

## Contractual warranty

Warranty	18 months
----------	-----------

Double Pedal Metal Foot Switch with Protective Cover

Dimensions

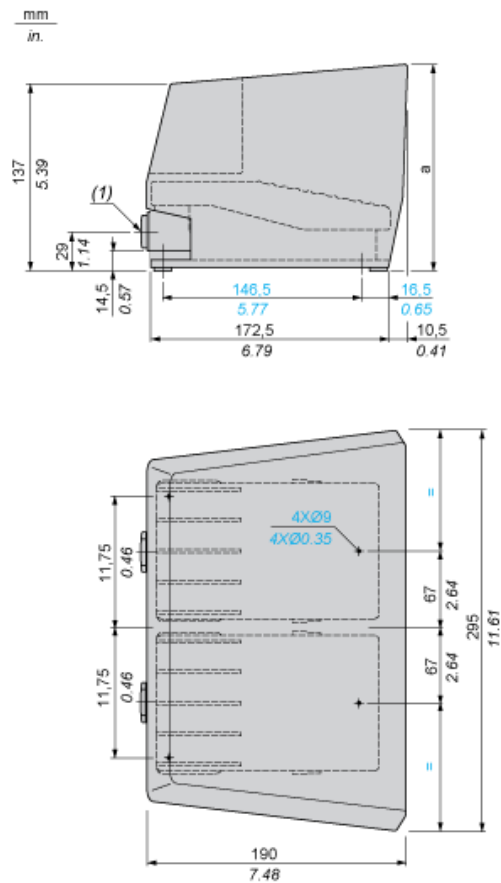

(1) 2 tapped entries for n° 16 (Pg 16) cable gland. For ISO M20, use adaptor DE9RA620.

---

Electrical Durability of Contacts

---

AC-15 Utilization Category

Operating rate: 3600 operating cycles/hour. Load factor: 0.5.

Inductive circuit:



X Current in A

Y Millions of operating cycles

DC-13 Utilization Category

Refer to the product characteristic "Operational power in W".