



Main

| | |
|---|--|
| Range of product | OsiSense XM |
| Product or component type | Electromechanical pressure sensor |
| Pressure sensor type | Electromechanical pressure sensor |
| Device short name | XMLB |
| Pressure rating | 20 bar |
| Controlled fluid | Air (0...70 °C) Fresh water (0...70 °C) Hydraulic oil (0...70 °C) |
| Fluid connection type | G 1/4 (female) conforming to ISO 228 |
| Electrical connection | 1 male connector EN 175301-803-A (ex DIN43650), 4 pins |
| Contacts type and composition | 1 C/O |
| Product specific application | - |
| Pressure switch type of operation | Regulation between 2 thresholds |
| Electrical circuit type | Control circuit |
| Scale type | Adjustable differential |
| Local display | With |
| Adjustable range of switching point on rising pressure | 1.3...20 bar |
| Adjustable range of switching point on falling pressure | 0.3...18.4 bar |
| Possible differential maximum at high setting | 11 bar |
| Maximum permissible accidental pressure | 45 bar |
| Destruction pressure | 90 bar |
| Pressure actuator | Diaphragm |
| Materials in contact with fluid | Nitrile Brass Zinc alloy |
| Enclosure material | Zinc alloy |
| [In] rated current | 3 A, B300, AC-15 (Ue = 120 V) conforming to EN/IEC 60947-5-1 1.5 A, B300, AC-15 (Ue = 240 V) conforming to EN/IEC 60947-5-1 0.1 A, R300, DC-13 (Ue = 250 V) conforming to EN/IEC 60947-5-1 |

Complementary

| | |
|---|------------------------|
| Possible differential minimum at low setting | 1 bar (+/- 0.25 bar) |
| Possible differential minimum at high setting | 1.6 bar (+/- 0.25 bar) |
| Maximum permissible pressure - per cycle | 25 bar |
| Terminal block type | 4 terminals |
| Maximum operating rate | 120 cyc/mn |
| Repeat accuracy | 2 % |

The information provided in this documentation contains general descriptions and/or technical characteristics of the performance of the products contained herein. This documentation is not intended as a substitute for and is not to be used for determining suitability or reliability of these products for specific user applications. It is the duty of any such user or integrator to perform the appropriate and complete risk analysis, evaluation and testing of the products with respect to the relevant specific application or use thereof. Neither Schneider Electric Industries SAS nor any of its affiliates or subsidiaries shall be responsible or liable for misuse of the information contained herein.

| | |
|--|---|
| [Ui] rated insulation voltage | 300 V conforming to UL 508 500 V conforming to EN/IEC 60947-1 300 V conforming to CSA C22.2 No 14 |
| [Uimp] rated impulse withstand voltage | 6 kV EN/IEC 60947-1 |
| Auxiliary contacts operation | Snap action |
| Contacts material | Silver contacts |
| Maximum resistance across terminals | 25 MOhm conforming to IEC 255-7 category 3 25 mOhm conforming to NF C 93-050 method A |
| Short-circuit protection | 10 A cartridge fuse, type gG (gl) |
| Mechanical durability | 5000000 cycles |
| Setting | External |
| Height | 113 mm |
| Depth | 75 mm |
| Width | 35 mm |
| Net weight | 0.735 kg |

Environment

| | |
|---------------------------------------|--|
| Standards | UL 508 EN/IEC 60947-5-1 CE CSA C22.2 No 14 |
| Product certifications | CSA CCC UL BV LROS (Lloyds register of shipping) EAC |
| Protective treatment | TC standard version |
| Ambient air temperature for operation | -25...70 °C |
| Ambient air temperature for storage | -40...70 °C |
| Operating position | Any position |
| Vibration resistance | 4 gn conforming to IEC 60068-2-6 (f = 30...500 Hz) |
| Shock resistance | 50 gn conforming to IEC 60068-2-27 |
| Electrical shock protection class | Class I conforming to IEC 1140 Class I conforming to IEC 536 Class I conforming to NF C 20-030 |
| IP degree of protection | IP65 conforming to EN/IEC 60529 |

Packing Units

| | |
|------------------------------|-----------|
| Unit Type of Package 1 | PCE |
| Number of Units in Package 1 | 1 |
| Package 1 Weight | 764 g |
| Package 1 Height | 4 cm |
| Package 1 width | 11.3 cm |
| Package 1 Length | 12 cm |
| Unit Type of Package 2 | S02 |
| Number of Units in Package 2 | 13 |
| Package 2 Weight | 10.349 kg |
| Package 2 Height | 15 cm |
| Package 2 width | 30 cm |
| Package 2 Length | 40 cm |

Offer Sustainability

| | |
|----------------------------|--|
| Sustainable offer status | Green Premium product |
| REACH Regulation | REACH Declaration |
| EU RoHS Directive | Pro-active compliance (Product out of EU RoHS legal scope) EU RoHS Declaration |
| Mercury free | Yes |
| RoHS exemption information | Yes |
| Environmental Disclosure | Product Environmental Profile |

Contractual warranty

| | |
|----------|-----------|
| Warranty | 18 months |
|----------|-----------|

Dimensions

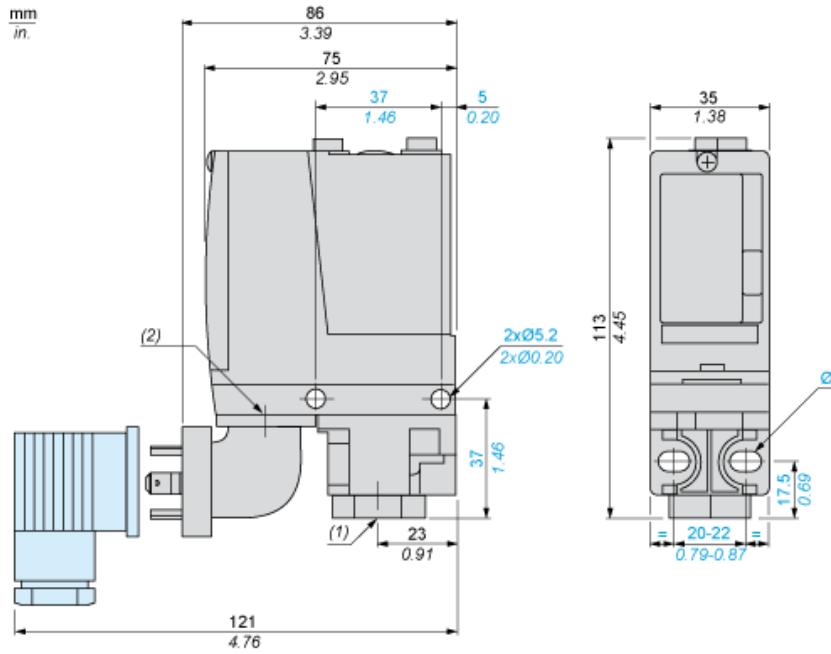

- (1) 1 fluid entry, tapped G1/4 (BSP female)
(2) EN 175301-803-A connector
Ø : 2 elongated holes Ø 5.2 x 6.7

Wiring Diagram

Terminal Model



Wiring Diagram

Vacuum Switch Connector Pin View

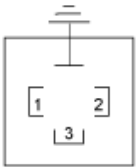

- (1) 11 and 13
- (2) 12
- (3) 14

Operating Curves

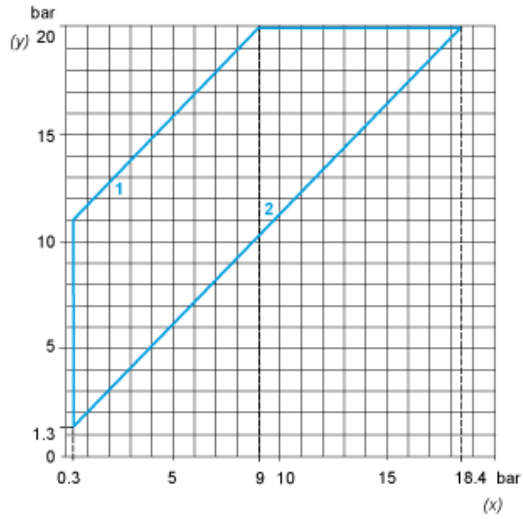

- (y) Rising pressure
- (x) Falling pressure
- 1 : Maximum differential
- 2 : Minimum differential

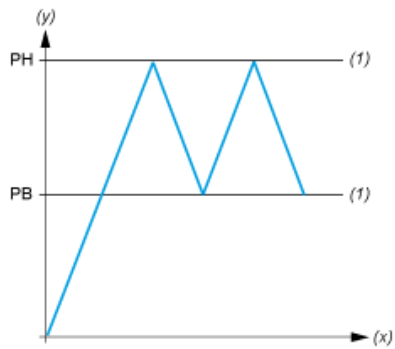

- (y) Pressure
- (x) Time
- (t) Adjustable value
- PH : High point
- PB : Below point